

Conductivity Sensor *OLS 50*

Highly resistant Inductive Conductivity Sensor for Standard and High-Temperature Applications



The conductivity sensor OLS 50 is specially suitable for use in the chemical industry and in process engineering. The six-decade measuring range and high chemical resistance of the material in contact with the medium (PEEK) permit this sensor to be used in virtually any application conceivable. The wide temperature range of -20 to $+125$ °C leaves nothing to be desired.

Areas of application

- Chemical industry
 - Concentration measurement of acids and alkalis
 - Product quality monitoring of chemical products in tanks and pipelines
- Phase separation of product/product mixtures in pipe systems in food and pharma industry

Benefits at a glance

- Measuring range from $5 \mu\text{S/cm}$ to 2000 mS/cm
- Chemical resistance due to PEEK coating
- PEEK version for high temperatures up to 125 °C
- Total cable length of up to 55 m
- Integrated, coated Pt 100 temperature sensor, error class A
- Large sensor opening, therefore low risk of soiling
- Can be installed in $\geq \text{DN } 80$ tees with the outgoing diameter reduced to $\geq \text{DN } 50$

Operating principle

Measuring and operating principle

- 1 Measuring instrument
- 2 Cable
- 3 Transmitting coil
- 4 Sensor opening
- 5 Receiving coil
- 6 Sensor housing
- 7 Medium
- 8 Induced electric current

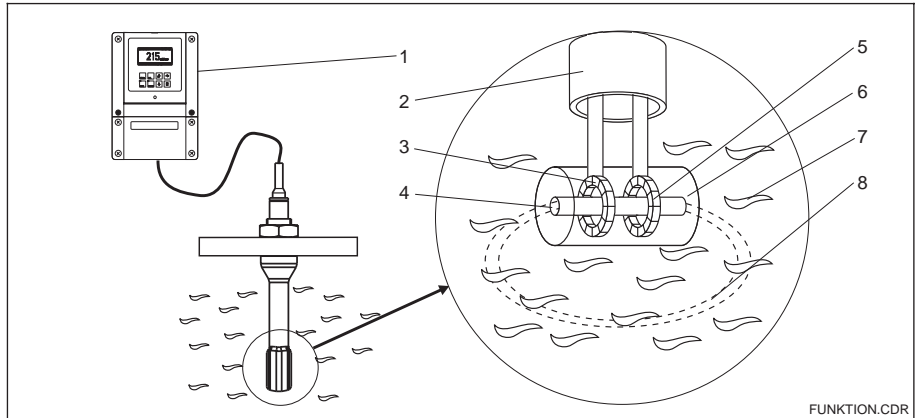

Conductivity measurement

In inductive conductivity measurement, a transmitting coil (3) generates a magnetic alternating field that induces an electric voltage in a liquid. The ions present in the liquid enable a current flow which increases with increasing ion concentrations. The ion concentration serves as a measure of conductivity. The current (8) in the liquid generates a magnetic alternating field in the receiving coil (5). The resulting current induced in the receiving coil is measured and used to determine the conductivity value.

The electric conductivity of the liquid primarily depends on the ion concentration. However, installation and sensor geometry are factors that need to be taken into account. The sensor constant describes the geometry of the sensor completely.

This measuring principle has the following advantages:

- No electrodes, therefore no polarisation
- Error-free measurement in strongly soiled media with a tendency to sediment
- Complete galvanic separation of measurement from medium.

Cell constant and installation factor

If the distance from the wall is sufficient ($a > 30 \text{ mm}$), then it is not necessary to consider the installation factor ($f = 1.00$). If the distance from the wall is smaller, then the installation factor increases in the case of electrically insulating pipes ($f > 1$) and decreases in the case of electrically conductive pipes ($f < 1$).

Installation

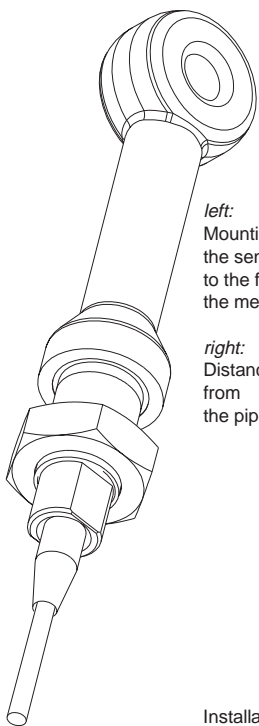

left:
Mounting position of the sensor with respect to the flow direction of the medium

right:
Distance a of the sensor from the pipe wall

Installation factor f in dependence on distance a from pipe wall

- 1 Conductive pipe
- 2 Insulating pipe

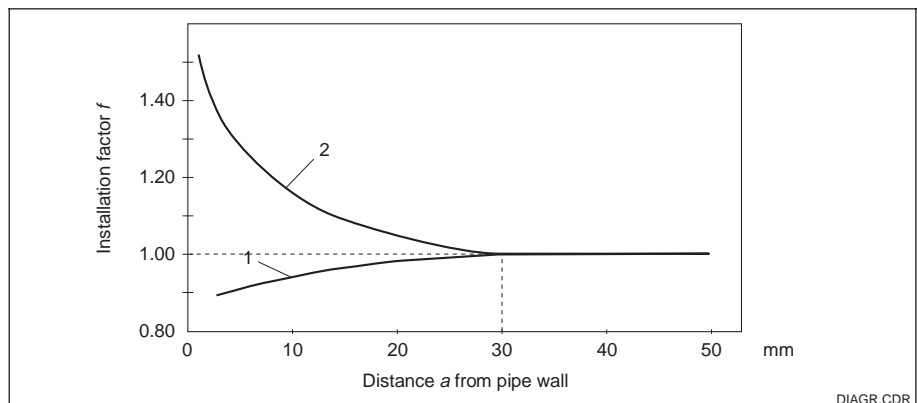
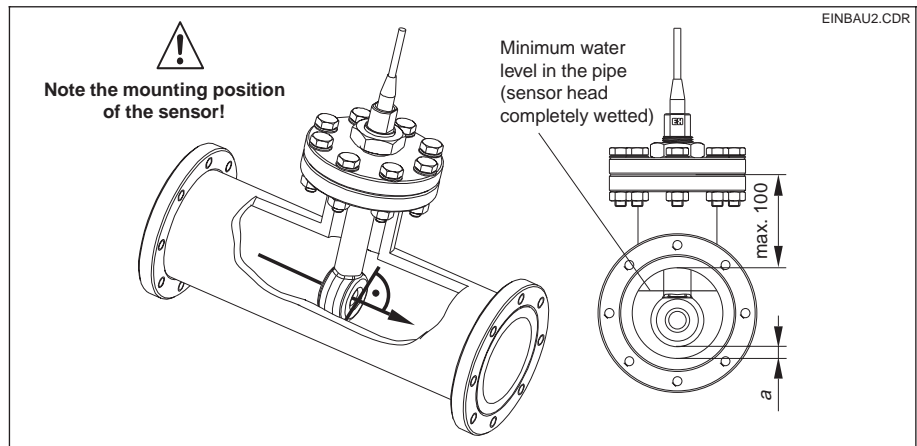

Dimensions

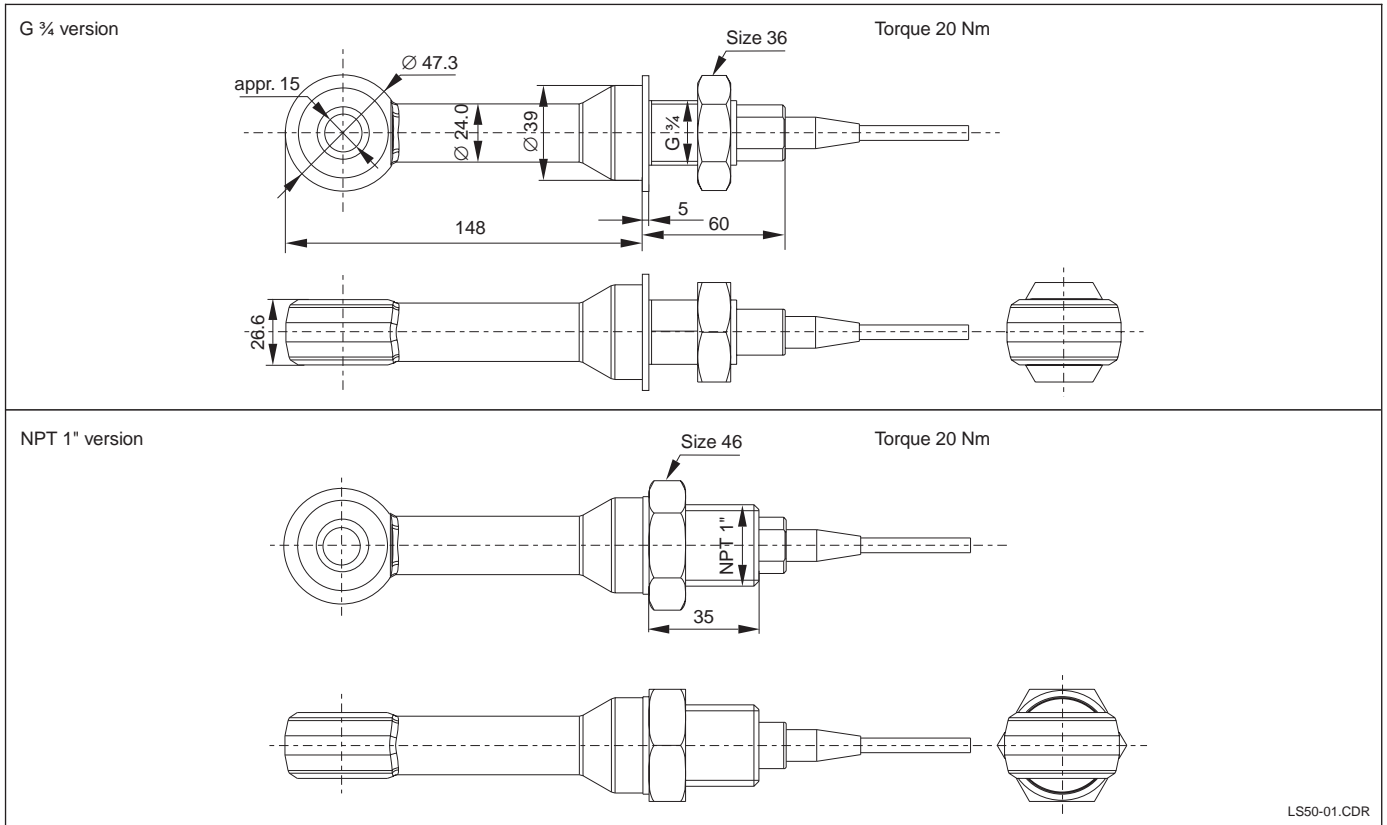

Dimensions: Versions with G 3/4 thread (top) and NPT 1" thread (bottom)

Mounting of sensor with assembly and G 3/4 version

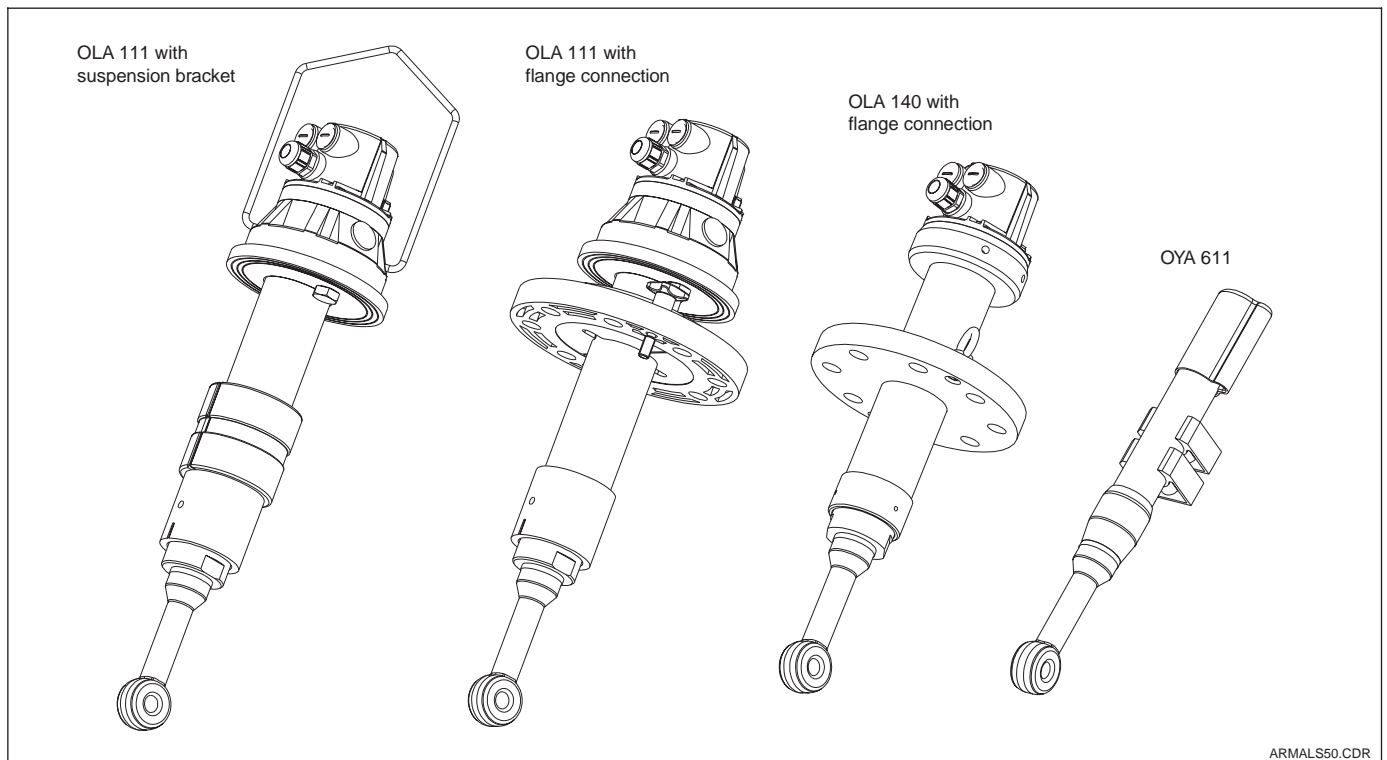

Assembly mounting of sensor, G 3/4 version

Mounting of sensor with flange

Fixed Flange, not in contact with medium

- 1 Nut
- 2 Flange
- 3 Sealing disk
- 4 Distance ring
- 5 Sealing
- 6 Sensor

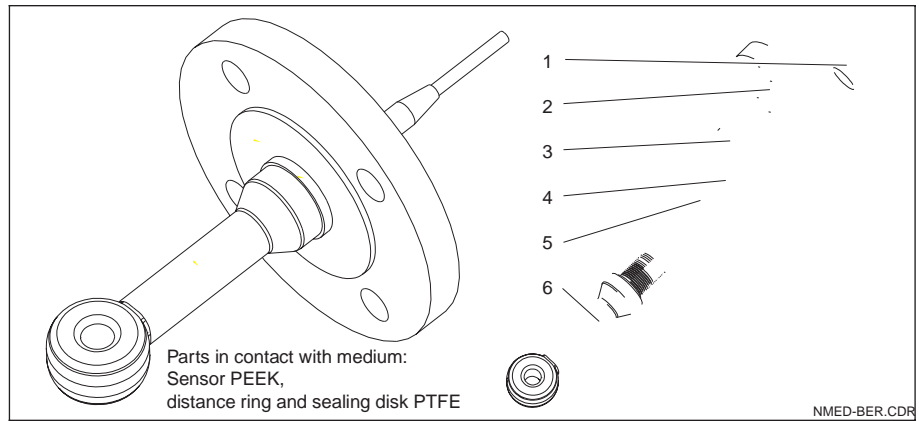

Fixed Flange, in contact with medium

- 1 Nut
- 2 Flange
- 3 Sealing
- 4 Sensor

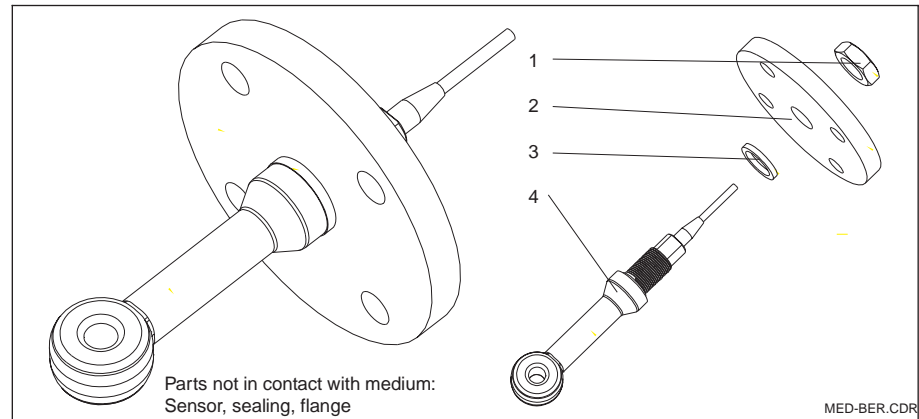

Flange dimensions

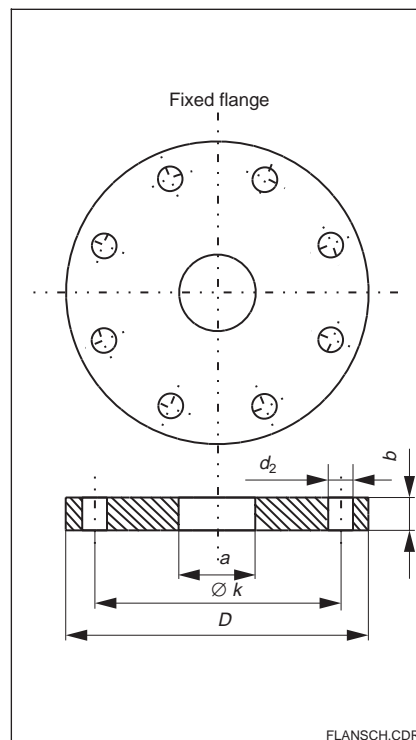

Fixed flange SS 316L	DN 50 PN 16
D	165
$\varnothing k$	125
d_2	4 x 18
b	18
a	27
Screws	M 16

Cable connection

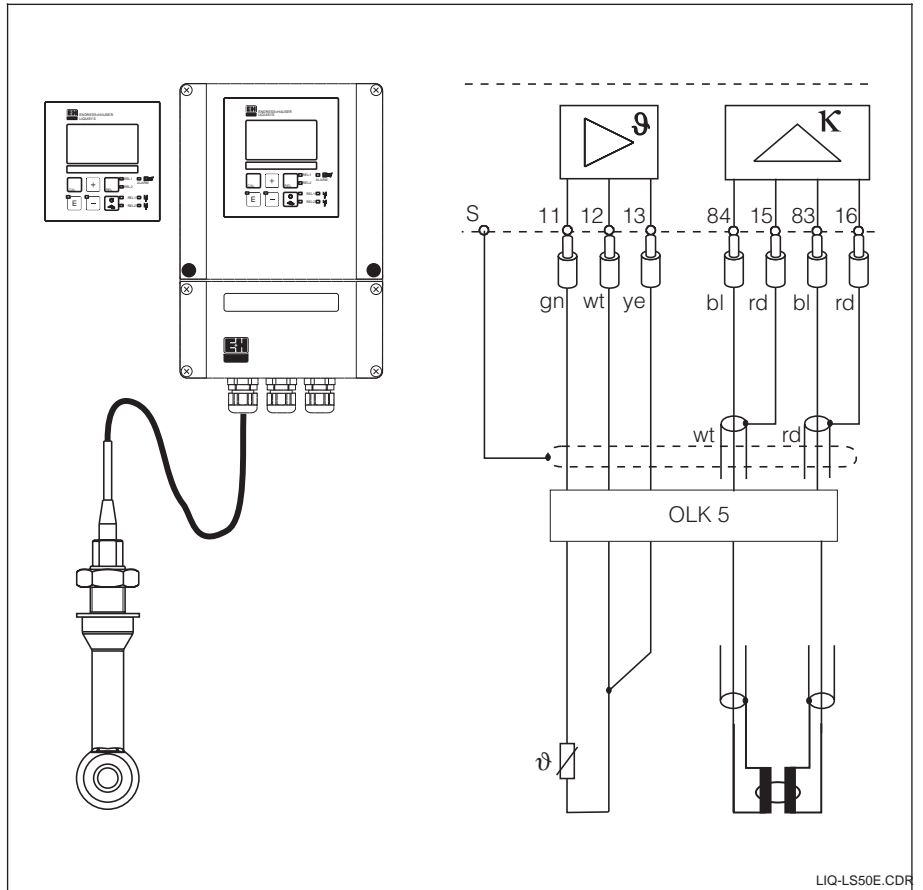

Accessories / service kits

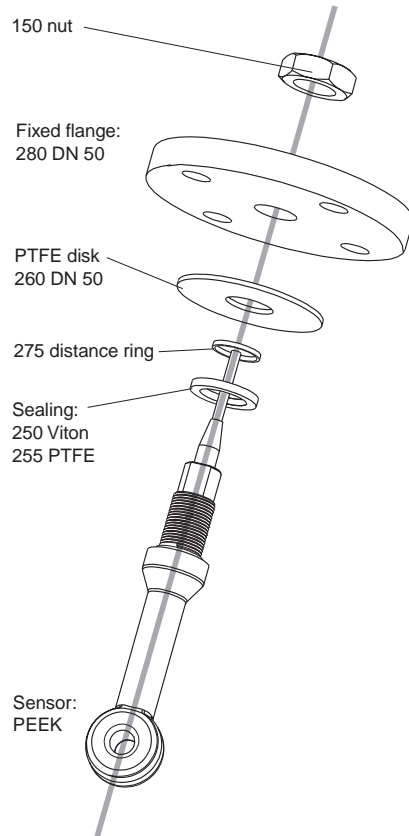

Sealing kits

- Kit OLS 50 PTFE sealing
Order no. 51500482
Pos. 150, nut
Pos. 255, PTFE sealing (2 pcs.)
- Kit OLS 50 Viton sealing
Order no. 51500481
Pos. 150, nut
Pos. 250, Viton sealing (3 pcs.)
- Kit OLS 50 PTFE disk DN 50
Order no. 51500483
Pos. 275, distance ring

Kits for fixed flanges

- Kit OLS 50 flange DN 50, SS 316L
Order no. 51500525
Pos. 150, nut
Pos. 280, flange DN 50
(Kit OLS 50 PTFE disk DN 50 additionally required for aggressive media!)

Accessories

- Extension cable OLK 5
Order no. 50085473
- Immersion assembly OLA 140

Resistance table

Chemical attack			
Medium	Concentration [%]	Temperature [°C]	PEEK
Nitric acid HNO ₃	up to 5	20	+
		60	+
	up to 40	20	+
		60	-
Phosphoric acid H ₃ PO ₄	up to 10	20	+
		60	+
Sodium hydroxide solution NaOH	up to 3	20	+
		50	+
		80	+

Resistances
PEEK
+ resistant
- not resistant

Pressure-temperature curves

Pressure-temperature curves in dependence on material and flange version

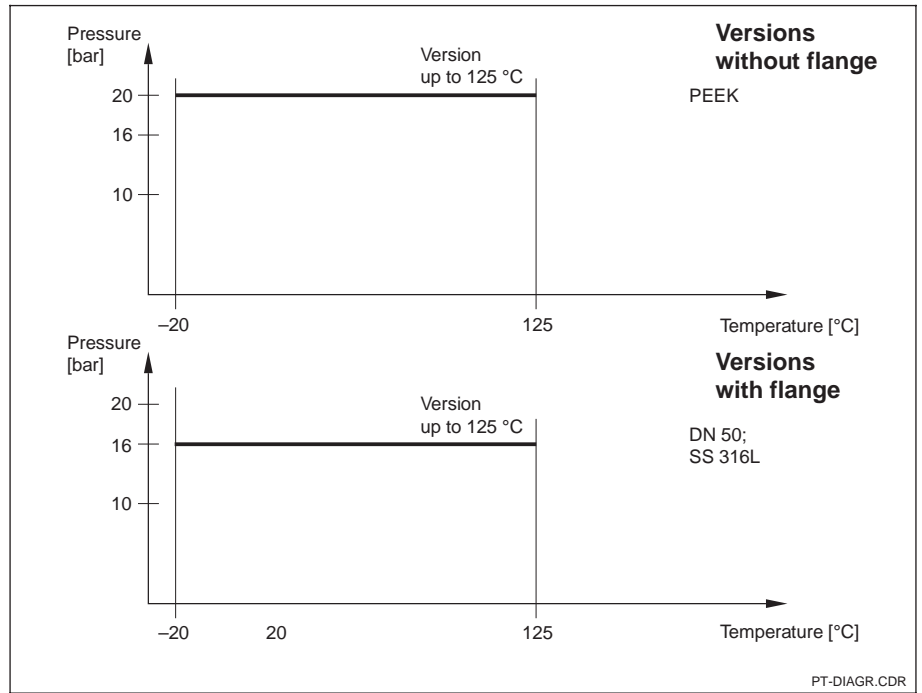

Technical data

Measuring range	5 µS/cm ... 2000 mS/cm
Cell constant	appr. 2 cm ⁻¹
Storage temperature	-20 ... +80 °C
Protection class (DIN 40050)	IP 67 (sensor in mounted state combined with original sealing)
Meas. value deviation for -20 ... 100 °C	±(5 µS/cm + 0.5 % of measured value)
Meas. value deviation for > 100 °C	±(10 µS/cm + 0.5 % of measured value)

Temperature measurement

Temperature sensor	Pt 100, class A acc. to IEC 751
Temperature response t_{90}	90 % of upper temperature display limit (acc. to DIN 746-1): approx. 7 min
- PEEK version	

Installation

Required pipe diameter	≥ DN 80 (consider installation factor if pipe diameter < DN 110)
Installation in reduced outgoing line	≥ DN 50

Subject to modifications.

Product structure

