

OLD 633 Conductivity Measurement

Compact conductivity transmitter with inductive sensor and integrated temperature compensation



The compact transmitter OLD 633 is used for inductive conductivity measurement in liquids of medium to high conductivity such as e.g. for process monitoring in galvanics. The transmitter can be used in temperature ranges of up to 70 °C.

Applications

- Water treatment
 - Galvanics
 - Photographic processes
 - Humidifiers and separators
- Cleaning plants
 - Vehicle systems
 - Rinsing processes
- Alkali monitoring
 - Tanning
 - Mordant preparation

Features and benefits

- Large measuring range between 0.2 ... 1000 mS/cm
- 9 selectable current output ranges
- Easy installation due to small size
- Temperature compensation through integrated temperature sensor Pt 100
- Sensor resistant to polarisation and soiling



Safety instructions



Warning!

This symbol alerts you to hazards which could cause serious injuries as well as damage to the instrument if ignored.



Caution:

This symbol alerts you to possible faults which could arise from incorrect operation. They could cause damage to the instrument if ignored.



Note:

This symbol indicates important items of information.

Functions and system design

The transmitter coil of the sensor creates an alternating magnetic field which induces an electrical current in the medium. The ions present in the medium form a current flow which creates a magnetic field in the receiver coil. The inductive current in the receiver coil is a measure of the medium's conductivity.

- 1 Oscillator
- 2 Receiver and signal processing
- 3 Cable
- 4 Primary winding
- 5 Secondary winding
- 6 Borehole
- 7 Sensor housing
- 8 Measuring medium
- 9 Induced current

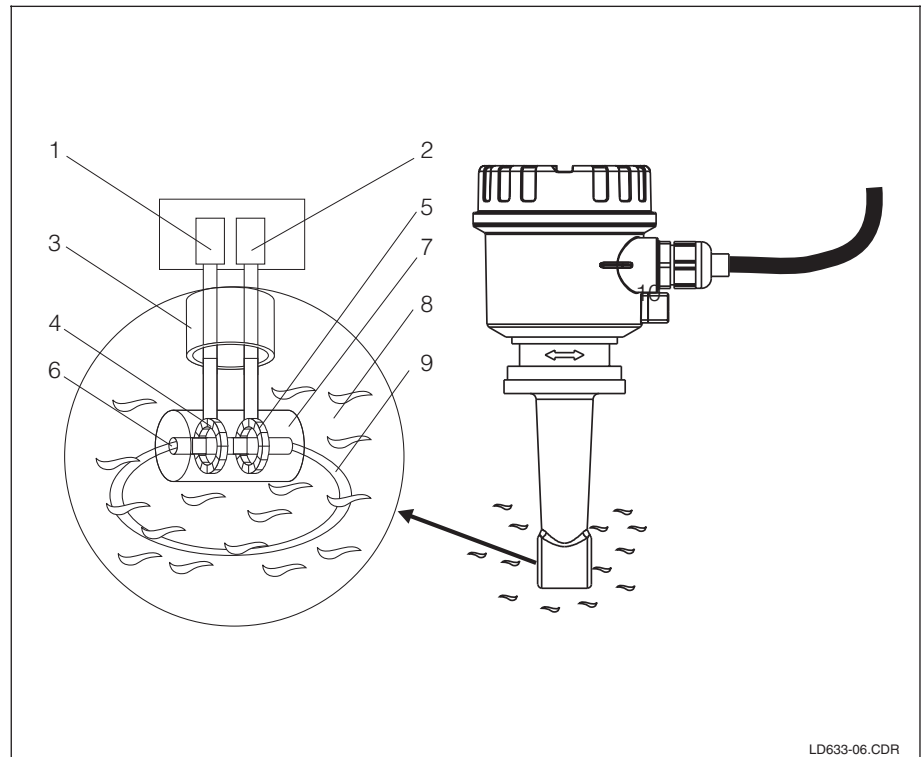

Dimensions

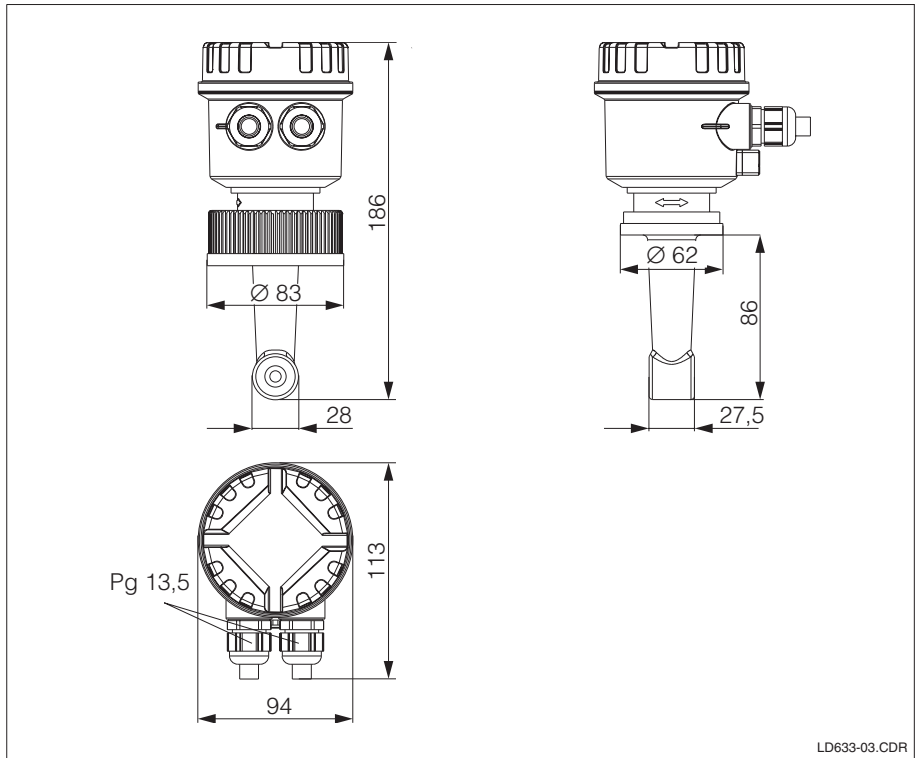

Dimensions
OLD 633

Installation

The compact device OLD 633 can be installed very easily:

- Place the device with the sensor in the opening of the piping carrying the medium or in the tank.
- Orientate the instrument in a way that the double arrow marks the flow direction. Then the sensor opening is aligned in flow direction.
- Tighten the coupling nut (2 ¼ ").
- A PVC adhesive support DN 40 with corresponding 2 ¼ " outer thread is available as an accessory (see Accessories). Stick the support into the intended sleeve, whilst keeping to the guidelines of the manufacturer. After the adhesive has dried, install the device as described.



Warning!

- Make sure your installation is straight. Avoid cross-threading to ensure the stability of the measuring point in pressurised processes.
- Make sure the sensor opening is situated in the middle of the pipe. In any case observe the minimum distance from the pipe wall.

Pipe installation
OLD 633
with PVC
adhesive
supports DN 40
(Accessories)

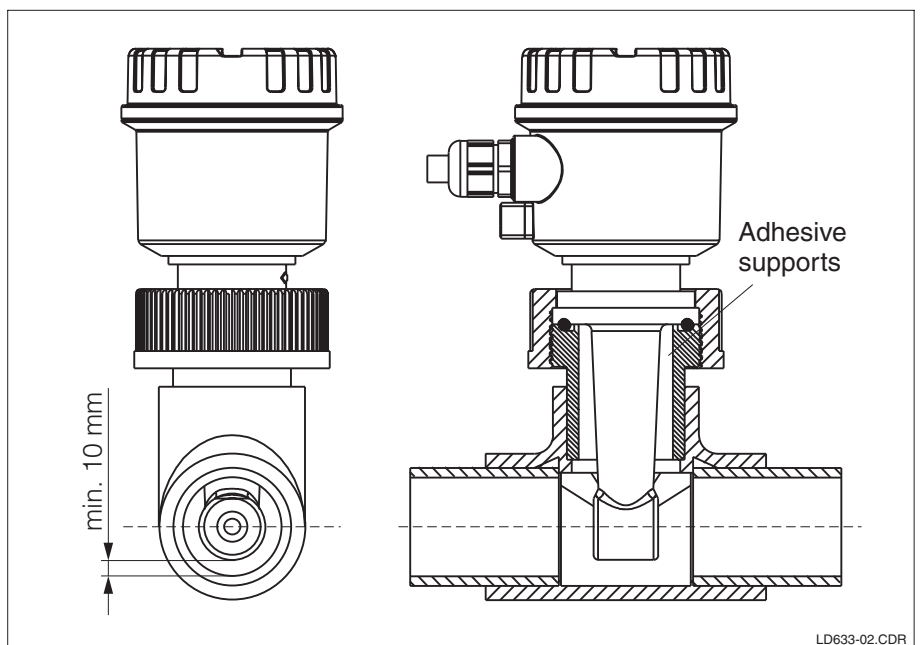

Electrical connection

Proceed as follows to make the electrical connection of the device:

- Insert the mains supply cable through the left-hand cable gland.
- Apply the 24 V supply voltage to terminals 24 V and GND.
- Insert the current output cable through the right-hand cable gland.
- Apply the conductivity current output to terminal mS.
- Apply the temperature current output to terminal °C.
- Apply both current outputs with earth to the terminal GND.



Caution!

- For wiring, use only screened cables.

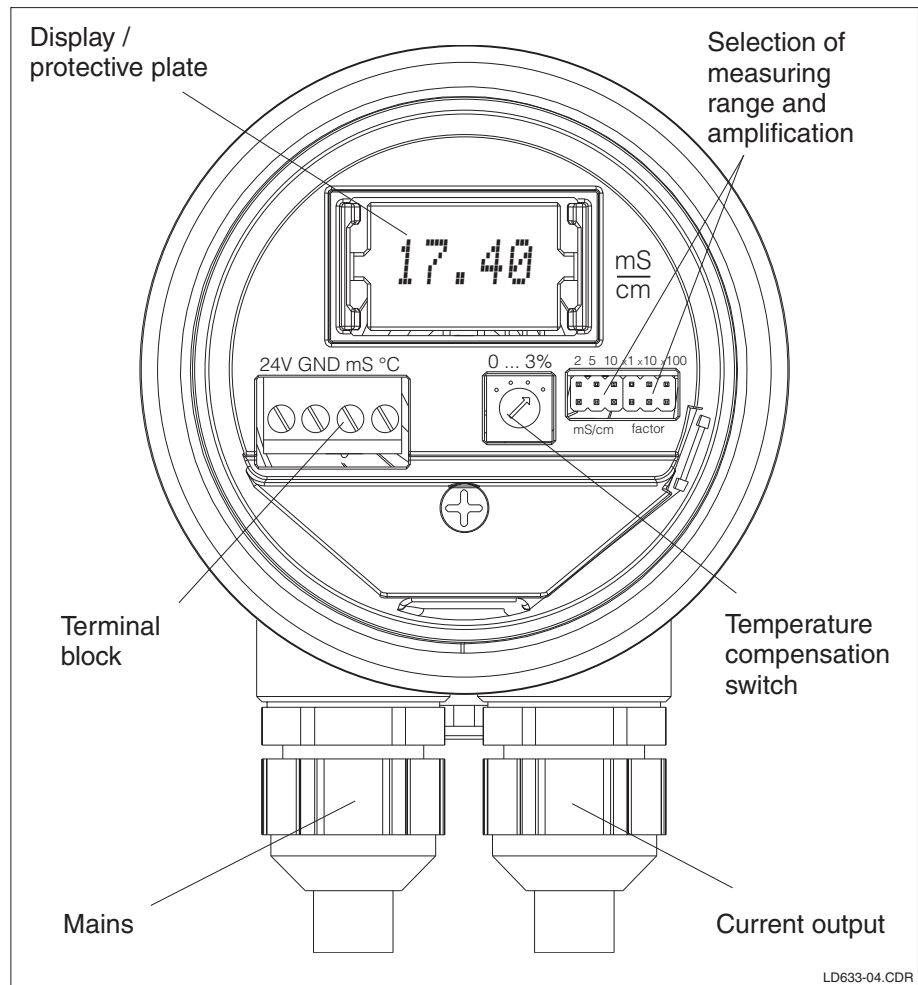

Electrical connection
OLD 633

LD633-04.CDR

Start-up

Adjusting the current output for conductivity:

For improved measuring range resolution, the current output range 4 ... 20 mA for conductivity can be adjusted with 2 jumpers on the right-hand side of the operating panel.

Select the measuring ranges as follows:

Measuring range [mS/cm]	0... 2	0...5	0...10	Factor 1	Factor 10	Factor 100
Contact pair	2	5	10	x 1	x 10	x 100

Example:

The measuring range 0 ... 200 mS/cm is set by placing the jumper on contacts 2 and 100.

The temperature current output is preset to the range 0 ... 150 °C.

Adjusting the temperature compensation:

Increasing the process temperature increases the conductivity of the measuring medium. Conversely, conductivity falls as the process temperature falls. This effect can be compensated with the medium temperature measured by the installed sensor.

To adjust the compensation, proceed as follows:

- Immerse the sensor in the measuring medium.
- Turn the temperature compensation all the way to 0. This switches off the compensation.
- The medium temperature must have reached the desired reference temperature (e.g. 25 °C).
- Note the conductivity value on the display.
- Bring the sample of the measuring medium to a medium process temperature.
- Turn the compensation switch slowly to set the display to the noted value.

Display installation

Optionally, devices such as version GE2PP0 which do not have a display can be subsequently retrofitted with a display unit. For this, you can order a display kit (see Accessories). To install the display, proceed as follows:

- Unscrew the screw cap of the housing.
- Use a screwdriver to carefully break open the protective plate (see Figure Electrical connection, page 4).
- Plug in the display plug connector and screw the display into the holder. The ribbon cable connected must be pointing to the mS/cm symbol.
- Screw the enclosed sight glass cover on.

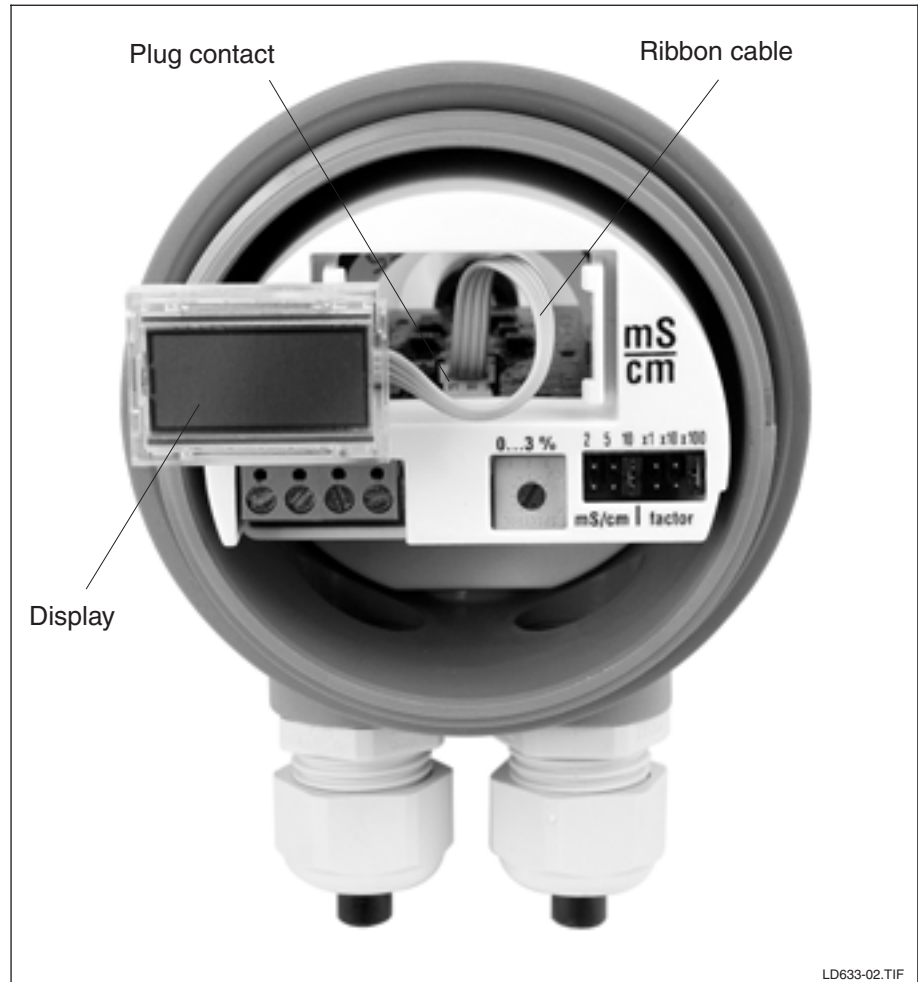

Display design
OLD 633

LD633-02.TIF



Note:

The moving bar shows the continuous measurement. It provides a continuous function control at a glance even with little changes in process conditions.

Maintenance

The compact device OLD 633 requires very little maintenance due to its practical flow design. To maintain reliable measurement, please remove coatings on sensor in coating media at regular intervals.



Note:

Coatings can usually be prevented by installing the sensor in flowing media.

Technical data

General data

Product designation	OLD 633
---------------------	---------

Mechanical construction

Dimensions (L x B)	186 x 113 mm
Cable gland	2 x Pg 13.5
Weight	approx. 0.5 kg
Measured value display	LC display, one line

Materials

Housing	PBT
Sensor	PP

Input parameters

Measuring range conductivity	0.2 ... 1000 mS/cm
temperature	0 ... 150 °C
Display measuring error	5% of measured value
Display resolution	at least $\pm 40 \mu\text{S/cm}$
Repeatability	0.5% of measured value
Temperature sensor	Pt 100
Temperature compensation	0 ... 70 °C

Output parameters

Current range	4 ... 20 mA, 9 selectable steps
Load	max. 500 Ω
Resolution	0.1% of measuring range
Measuring error	5% of current output range

Electrical connection data

Power supply	24 VDC
Power consumption	5 W

Process conditions

Operating temperature range	0 ... +70 °C
Operating pressure range	8 bar / 40 °C, 1 bar / 70 °C

Ambient conditions

Storage temperature	-10 ... +50 °C
Ingress protection	IP 65
Electromagnetic compatibility	Interference emission and immunity acc. to EN 61326:1997 / A1:1998

Subject to modification.

Pressure-temperature chart

Pressure/
temperature
chart

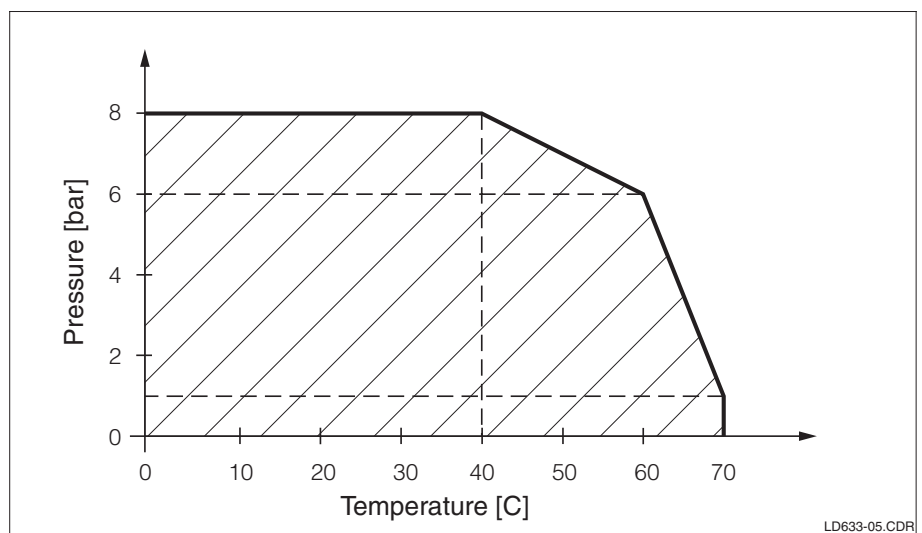

LD633-05.CDR

Accessories

- Adhesive support PVC DN 40
Order No.: 51509484
- Display kit
consisting of display and sight glass cover
Order No.: 51509485

Product structure

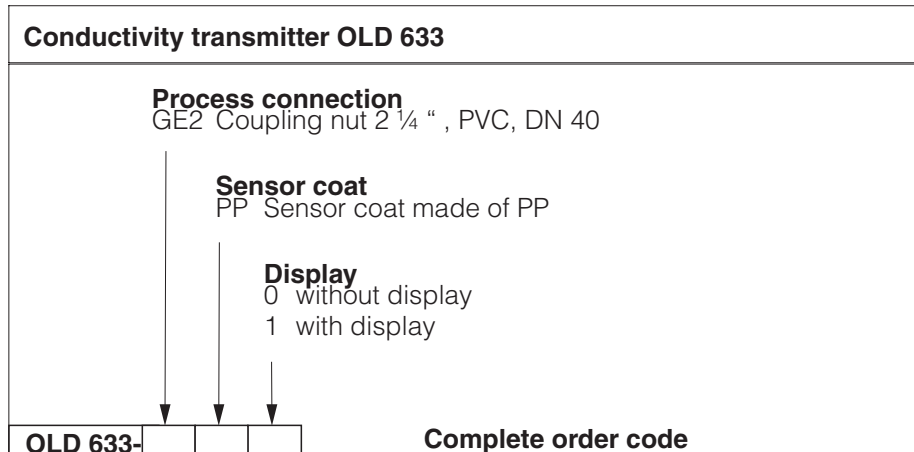

Use the product structure to identify your device on the nameplate.

OLD 633 conductivity ind./ Leitfähigkeit ind.		CE
order code / Best.Nr.: OLD 633-GE2PP0		
serial no. / Ser.-Nr.: 123456 Codes: /		
measuring range / Messbereich : 0.2 ... 1000 mS/cm		
output 1 / Ausgang 1: 4 ... 20 mA (range selectable)		
output 2 / Ausgang 2: 4 ... 20 mA (0 ... 150 °C)		
mains / Netz : 24 V DC 5W		
prot. class / Schutzart		: IP65
ambient temp. / Umgebungstemperatur		: -10 ... +50 °C
operating temp. / Prozesstemperatur		: 0 ... +70 °C

133745-1415-4A