

# Assemblies for oxygen sensors OOS 4 / OOS 4HD OOA 110

## Oxygen measurement in immersion operation



### Areas of application

The immersion assemblies OOA 110 are designed to hold the oxygen sensors OOS 4 and OOS 4HD.

The OOA 110-40 version together with the universal suspension assembly holder OYH 101-A serves as a complete installation system for measuring transmitter and sensor and is particularly suitable for measurements in open basins or tanks (e.g. activated sludge basin in a sewage treatment plant).

The OOA 110-50 version enables oxygen measurement in lakes, rivers or basins with considerable fluctuations of the water level.

### Benefits at a glance

- The immersion tube and sensor have the same outside diameter. Once the sensor is attached, the immersion tube and sensor form a single ridgeless unit effectively preventing dirt accumulation on the sensor.
- All assemblies are designed so that water motion causes a slight oscillating movement of the immersion tube. This results in an additional cleaning effect on the sensor membrane surface.

## Dimensions

Immersion holder  
OOA 110-40

- 1 Mounting bracket
- 2 Protection cover for cable entry
- 3 Lead pipe for stabilization
- 4 G1"-internal thread for oxygen sensor OS 4/OOS 4HD

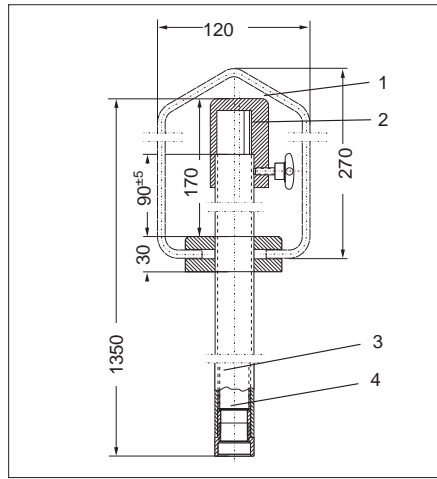

- 1 Cable strain relief
- 2 Cable outlet and rain protection
- 3 Fixing ring with clamping screw
- 4 Eyelets Ø 15; 3 x 120° for attachment of assembly by means of fastening strings
- 5 Salt water-resistant plastic float
- 6 Stainless steel pipe 40 x 1 Material 1.4571
- 7 „Shock absorber“ weight for stabilization
- 8 Oxygen sensor OOS 4/OOS 4HD

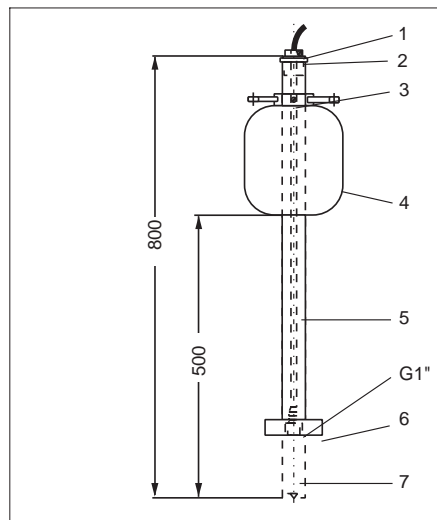

### OOA 110-40

The immersion assembly OOA 110-40 is attached to the universal suspension assembly holder OYH 101 (transverse pipe) with the stainless steel mounting bracket and a plastic chain. The height can be adapted to the local conditions by selecting the appropriate chain position. The integrated lead pipe secures the assembly in the vertical installation position. The sensor can be easily removed for cleaning, air calibration or general control.

### OOA 110-50

The OOA 110-50 float assembly consists of the float body made of salt water-resistant polyurethane foam. The immersion pipe (65 cm long) with G1" thread holds the sensor OOS 4.

Three eyelets are arranged in an angle of 120° (attached on the fixing ring above the body) for attachment of fastening strings.

An additional weight on the lower end increases the lateral stability and serves as a shock absorber. The pendulum motion of the immersion pipe has a cleaning effect on the sensor membrane. The immersion depth of the sensor tip is approx. 60 cm below the water level.

## How to order

### O<sub>2</sub>-Assembly OOA 110

#### Version

- 40 PVC 1.30 m + mounting bracket V4A  
50 V4A 0.65 cm / PUR floating body

OOA 110 - [ ] [ ] [ ] [ ] [ ]

complete order code

## Accessories

- Mounting bracket V4A 50016475
- OP baffle plate, protection under extreme flow conditions 50028712

ISI Europa  
P. O. Box 10 01 54  
D-70826 Gerlingen  
Tel. +49-71 56-2 09-2 18  
Fax +49-71 56-2 65 71

