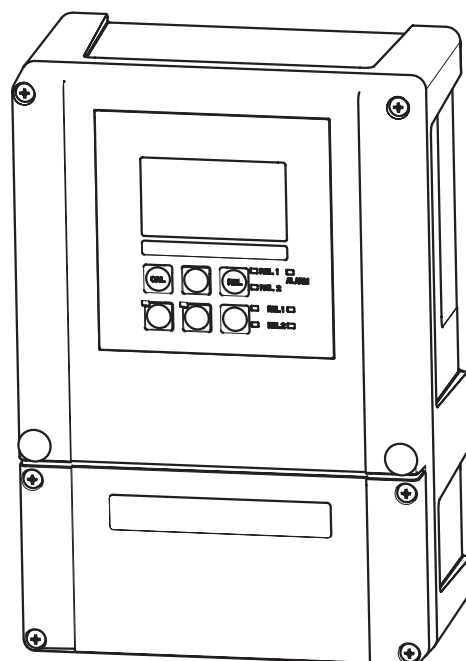
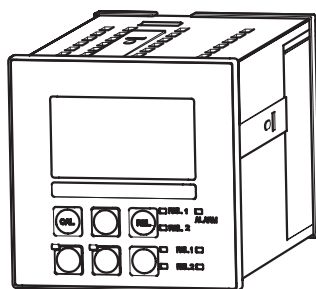


Operating Instructions

OOM223/253

Transmitter for Dissolved Oxygen



Brief operating instructions

This explains how to use these Operating Instructions to commission your transmitter quickly and safely:

Page 4 ff. Page 5 ff.	Safety instructions General safety instructions Explanation of the warning symbols You can find special instructions at the appropriate position in the chapter in question. The positions are indicated with the icons Warning ⚠, Caution ⚡ and Note 📌
Page 9 ff. Page 11 ff.	Installation Here you can find information on installation conditions and the dimensions of the transmitter. You can find information on how to install the transmitter on these pages.
Page 15 ff.	Wiring Here you can find out how to connect sensors to the transmitter.
Page 28 ff. Page 32 ff. Page 39 ff. Page 66 ff.	Operation The display and operating elements are described here. The operating concept is explained here. The system configuration is explained here. You can find information on how to calibrate the sensor on these pages.
Page 70 ff. Page 74 ff. Page 78 ff. Page 86 ff.	Maintenance Here you can find information on the maintenance of the entire measuring point. The accessories which can be delivered for the transmitter are listed on the pages indicated. Here you can find information on trouble-shooting. Here you can find an overview of the spare parts which can be delivered as well as an overview of the system.
Page 9 ff. Page 93 ff.	Technical data Dimensions Ambient and process conditions, weight, materials etc.
Page 98 ff.	Appendix Here you can find the operating matrix

Table of contents

1	Safety instructions	4	8	Accessories	74
1.1	Designated use	4	8.1	Sensors	74
1.2	Installation, commissioning and operation	4	8.2	Connection accessories	74
1.3	Operational safety	4	8.3	Mounting accessories	75
1.4	Return	5	8.4	Assemblies	76
1.5	Notes on safety icons and symbols	5	8.5	Software and hardware add-ons	77
			8.6	Optoscope	77
2	Identification	6	9	Trouble-shooting	78
2.1	Device designation	6	9.1	Trouble-shooting instructions	78
2.2	Scope of delivery	7	9.2	System error messages	78
2.3	Certificates and approvals	7	9.3	Process specific errors	81
3	Installation	8	9.4	Instrument specific errors	84
3.1	Quick installation guide	8	9.5	Spare parts	86
3.2	Incoming acceptance, transport, storage	9	9.6	Return	92
3.3	Installation conditions	9	9.7	Disposal	92
3.4	Installation instructions	11	10	Technical data	93
3.5	Post-installation check	14	10.1	Input	93
4	Wiring	15	10.2	Output	93
4.1	Electrical connection	15	10.3	Power supply	94
4.2	Post-connection check	27	10.4	Performance characteristics	95
5	Operation	28	10.5	Environment	95
5.1	Quick operation guide	28	10.6	Mechanical construction	96
5.2	Display and operating elements	28	11	Appendix	98
5.3	Local Operation	32		Index	110
6	Commissioning	35			
6.1	Function check	35			
6.2	Switching on	35			
6.3	Quick start-up	37			
6.4	System configuration	39			
6.5	Communication	66			
6.6	Calibration	66			
7	Maintenance	70			
7.1	Maintenance of the entire measuring point	70			
7.2	"Optoscope" service tool	73			

1 Safety instructions

1.1 Designated use

OOM223/253 is a transmitter for determining the oxygen concentration of a liquid medium.

The transmitter is particularly suited for use in the following areas:

- Sewage treatment plants
- Sewage treatment
- Drinking water
- Water conditioning and monitoring
- Surface water (rivers, lakes, oceans)
- Fish farming

Any other use than the one described here compromises the safety of persons and the entire measuring system and is, therefore, not permitted.

The manufacturer is not liable for damage caused by improper or non-designated use.

1.2 Installation, commissioning and operation

Please note the following items:

- Installation, electrical connection, commissioning, operation and maintenance of the measuring system must only be carried out by trained technical personnel.
The technical personnel must be authorised for the specified activities by the system operator.
- Technical personnel must have read and understood these Operating Instructions and must adhere to them.
- Before commissioning the entire measuring point, check all the connections for correctness. Ensure that electrical cables and hose connections are not damaged.
- Do not operate damaged products and secure them against unintentional commissioning. Mark the damaged product as being defective.
- Measuring point faults may only be rectified by authorised and specially trained personnel.
- If faults can not be rectified, the products must be taken out of service and secured against unintentional commissioning.
- Repairs not described in these Operating Instructions may only be carried out at the manufacturer's or by the service organisation.

1.3 Operational safety

The transmitter has been designed and tested according to the state of the art and left the factory in perfect functioning order.

Relevant regulations and European standards have been met.

As the user, you are responsible for complying with the following safety conditions:

- Installation instructions
- Local prevailing standards and regulations.

Ex systems have an additional Ex documentation which is part of the Operating Instructions (see also chapter "Scope of delivery").

EMC

This instrument has been tested for electromagnetic compatibility in industrial use according to applicable European standards.

Protection against interference as specified above is valid only for an instrument connected according to the instructions in these Operating Instructions.

1.4 Return

If the transmitter has to be repaired, please return it *cleaned* to the sales centre responsible. Please use the original packaging, if possible.

1.5 Notes on safety icons and symbols

Safety icons



Warning!

This symbol alerts you to hazards. They can cause serious damage to the instrument or to persons if ignored.



Caution!

This symbol alerts you to possible faults which could arise from incorrect operation. They could cause damage to the instrument if ignored.



Note!

This symbol indicates important items of information.

Electrical symbols



Direct Current (DC)

A terminal at which DC is applied or through which DC flows.



Alternating Current (AC)

A terminal at which (sine-form) AC is applied or through which AC flows.



Ground connecting

A terminal, which, from the user's point of view, is already grounded using a grounding system.



Protective earth terminal

A terminal which must be grounded before other connections may be set up.



Alarm relay



Input



Output



DC voltage source



Temperature sensor

2 Identification

2.1 Device designation

2.1.1 Product structure

Version			
DX			Sensor OOS41 / 4 / 4HD, basic functions
DS			Sensor OOS41 / 4 / 4HD, with additional functions (Plus package)
WX			Sensor OOS31 / 61 / 71 / 3 / 3HD, basic functions
WS			Sensor OOS31 / 61 / 71 / 3 / 3HD, with additional functions (Plus package)
Power supply; approval			
		0	230 V AC
		1	115 V AC
		2	230 V AC; CSA Gen. Purp.
		3	115 V AC; CSA Gen. Purp.
		4	230 V AC; ATEX II 3G [EEx nAL] IIC
		5	100 V AC
		6	24 V AC/DC; ATEX II 3G [EEx nAL] IIC for OOM223, EEx nA[L] IIC T4 for OOM253
		7	24 V AC/DC; CSA Gen. Purp.
		8	24 V AC/DC
Output			
		0	1 x 20 mA, dissolved oxygen
		1	2 x 20 mA, dissolved oxygen and temperature/actuating variable
		3	PROFIBUS PA
		4	PROFIBUS DP
		5	1 x 20 mA, dissolved oxygen with HART®
		6	2 x 20 mA, dissolved oxygen with HART® and temperature/actuating variable
Additional contacts; analog input			
		05	Not selected
		10	2 x relay (limit/controller/timer)
		15	4 x relay (limit/controller/Chemoclean)
		16	4 x relay (limit/controller/timer)
		20	2 x relay (limit/controller/timer); current input
		25	4 x relay with cleaning (limit/controller/timer/Chemoclean); current input
		26	4 x relay with timer (limit/controller/timer); current input
OOM253-			complete order code
OOM223-			

2.1.2 Additional functions of the Plus Package

- Current output table to cover large areas with varying resolution, fields O23x
- Process Check System (PCS): live check of the sensor, function group P
- Automatic cleaning function start, field F8
- At version DS: air pressure measurement

2.2 Scope of delivery

The delivery of the field instrument includes:

- 1 transmitter OOM253
- 1 plug-in screw terminal
- 1 cable gland Pg 7
- 1 cable gland Pg 16 reduced
- 2 cable glands Pg 13.5
- 1 operating instructions BA199e00
- versions with HART communication:
 - 1 operating instructions Field Communication with HART, BA208e00
- versions with PROFIBUS communication:
 - 1 operating instructions Field Communication with PROFIBUS PA/DP, BA209e00
- versions with explosion protection for hazardous area zone 2 (ATEX II 3G):
 - Safety instructions for use in explosion-hazardous areas, XA194a300

The delivery of the panel mounted instrument includes:

- 1 transmitter OOM223
- 1 set of plug-in screw terminals
- 2 tensioning screws
- 1 BNC-plug (solder-free)
- 1 operating instructions BA199e00
- versions with HART communication:
 - 1 operating instructions Field Communication with HART, BA208e00
- versions with PROFIBUS communication:
 - 1 operating instructions Field Communication with PROFIBUS PA/DP, BA209e00
- versions with explosion protection for hazardous area zone 2 (ATEX II 3G):
 - Safety instructions for use in explosion-hazardous areas, XA194a300

If you have any questions, please contact your supplier or your sales centre responsible.

2.3 Certificates and approvals

Declaration of conformity

The product meets the legal requirements of the harmonised European standards.

The manufacturer confirms compliance with the standards by affixing the **CE** symbol.

Explosion protection for Zone 2

Version	Approval
OOM253-..6...	ATEX II 3G EEx nA[L] IIC T4
OOM253-..4... OOM223-..4... OOM223-..6...	ATEX II 3G [EEx nAL] IIC

3 Installation

3.1 Quick installation guide



Warning!

If the measuring point or parts of the measuring point are in explosion-hazardous areas you have to follow the "Safety instructions for electrical apparatus certified for use in explosion-hazardous areas". These instructions (XA194a300) are part of the scope of delivery.

Proceed as follows to completely install the measuring point:

- Install the transmitter (see "Installation instructions" section).
- If the sensor is not yet installed in the measuring point, install it (see Technical Information of the sensor).
- Connect the sensor to the transmitter as illustrated in the "Electrical connection" section.
- Connect the transmitter as illustrated in the "Electrical connection" section.
- Commission the transmitter as explained in the "Commissioning" section.

3.1.1 Measuring system

A complete measuring system comprises:

Variant 1 (DX/DS with OOS41)

- The transmitter OOM223 or OOM253 in version DX or DS
- An oxygen sensor OOS41
- An immersion, flow or retractable assembly

Options: extension cable CMK, junction box VBM

Variant 2 (WX/WS with OOS31, OOS61 or OOS71)

- The transmitter OOM223 or OOM253 in version WX or WS
- An oxygen sensor OOS31, OOS61 or OOS71
- An immersion, flow or retractable assembly

Options: extension cable OMK, junction box VS

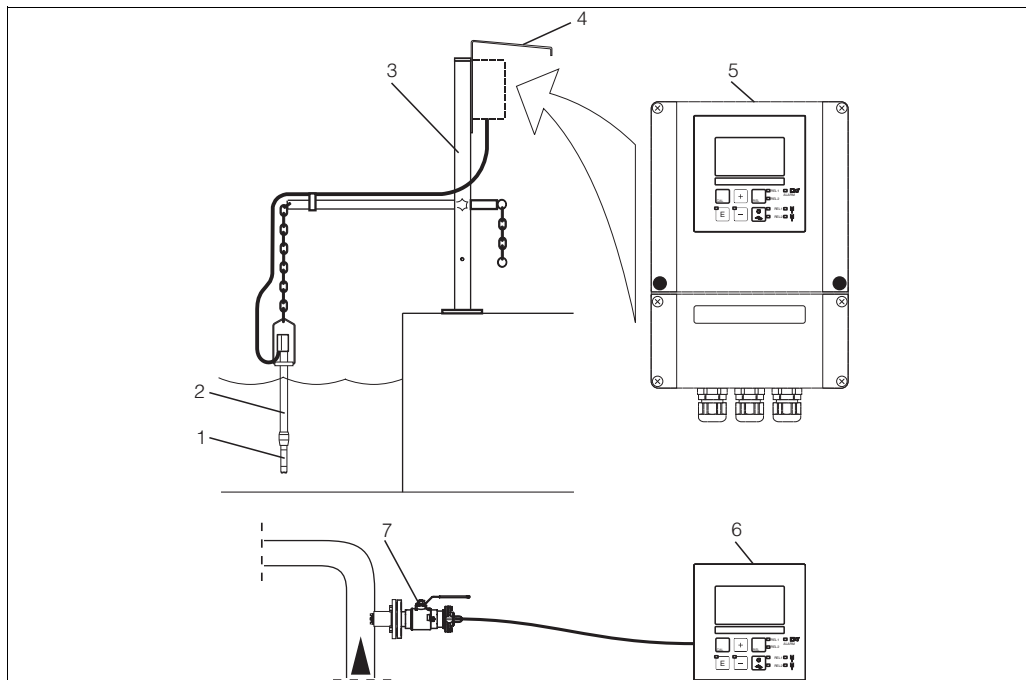


Fig. 1: Complete measuring system OOM223/253

C07-OOM2x3xx-14-06-00-xx-002.eps

- | | |
|--|-------------------------------|
| 1 Oxygen sensor | 5 Transmitter OOM253 |
| 2 Immersion assembly OYA611 | 6 Transmitter OOM223 |
| 3 Universal hanging assembly holder OYH101 | 7 Retractable assembly OOA451 |
| 4 Weather protection cover OYY101 | |

3.2 Incoming acceptance, transport, storage

- Make sure the packaging is undamaged!
Inform the supplier about damage to the packaging.
Keep the damaged packaging until the matter has been settled.
- Make sure the contents are undamaged!
Inform the supplier about damage to the delivery contents.
Keep the damaged products until the matter has been settled.
- Check that the scope of delivery is complete and agrees with your order and the shipping documents.
- The packaging material used to store or to transport the product must provide shock protection and humidity protection. The original packaging offers the best protection. Also, keep to the approved ambient conditions (see "Technical data").
- If you have any questions, please contact your supplier or your sales centre responsible.

3.3 Installation conditions

3.3.1 Field instrument

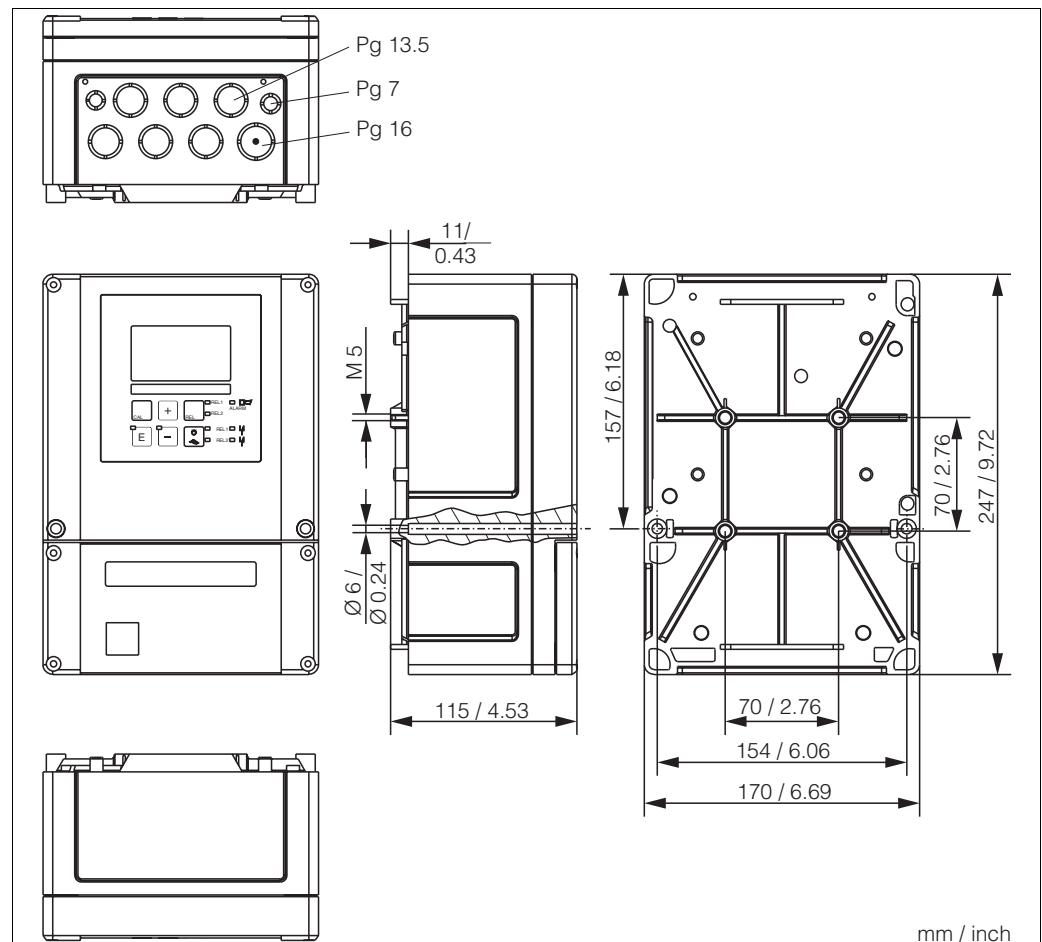


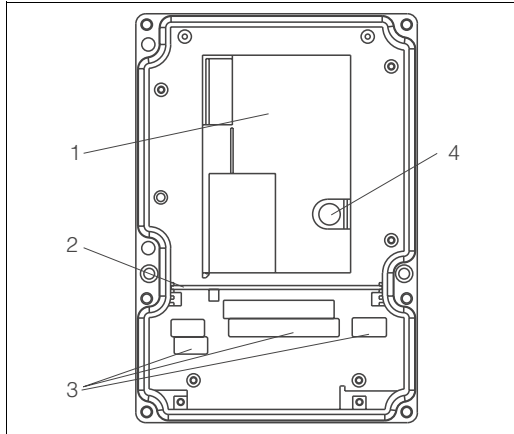
Fig. 2: Field instrument

mm / inch
C07-OxM253xx-06-06-00-en-001.EPS



Note!

There is a hole in the punching for the cable entry (connection of supply voltage). It serves as a pressure balance during air freight dispatching. Make sure no moisture penetrates the inside of the housing before the cable installation. The housing is completely air-tight after the cable installation.

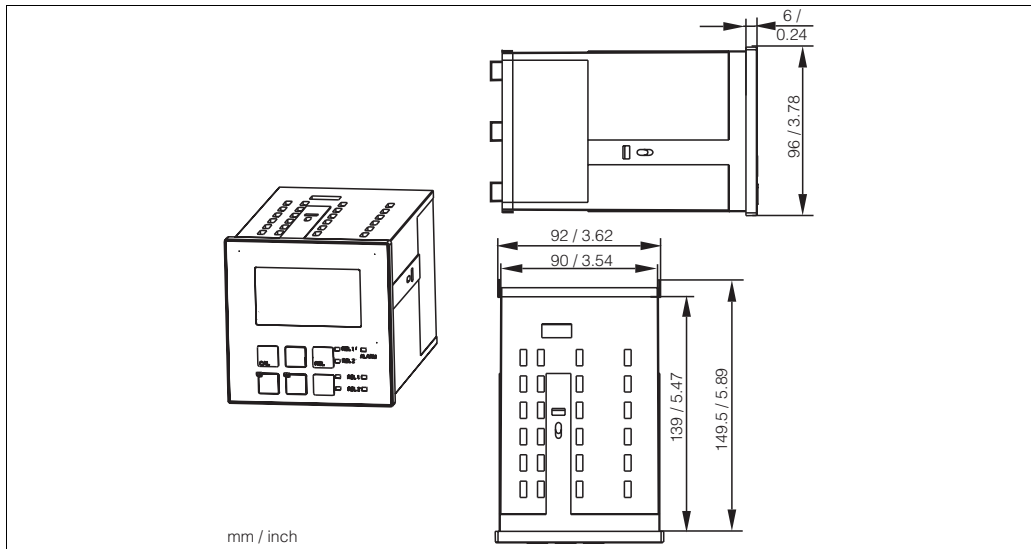


- 1 Removable electronics box
- 2 Partition plate
- 3 Terminals
- 4 Fuse

C07-OxM253xx-11-06-00-xx-001.eps

Fig. 3: View into the field housing

3.3.2 Panel-mounted instrument



C07-OxM223xx-06-06-00-en-001.EPS

Fig. 4: Panel-mounted instrument

3.4 Installation instructions

3.4.1 Field instrument

There are several ways of securing the field housing:

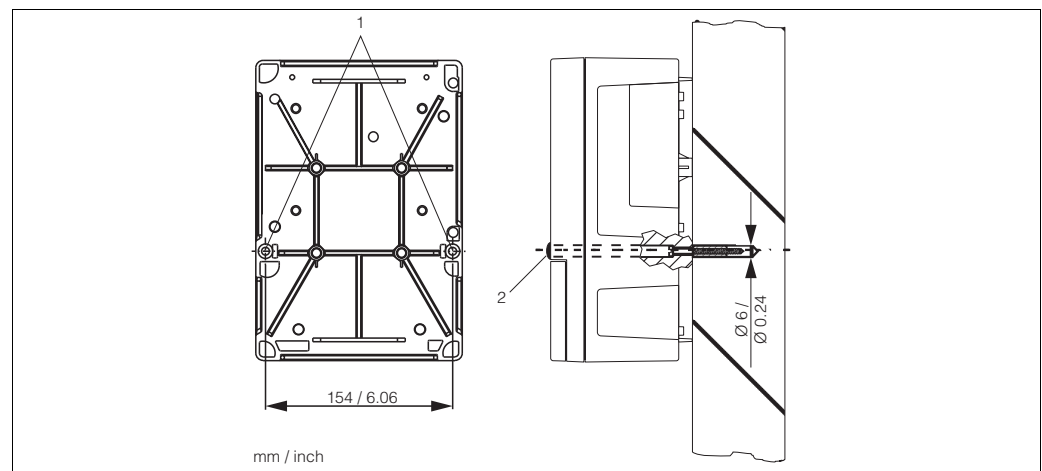
- Wall mounting with fixing screws
- Post mounting to cylindrical pipes
- Post mounting to square securing mast



Note!

When mounting in the open air with unprotected exposure to weather conditions, a weather protection cover (see Accessories) is required.

Transmitter wall mounting



C07-OxM253-11-06-00-en-002.eps

Fig. 5: Field instrument wall mounting

For wall mounting the transmitter, proceed as follows:

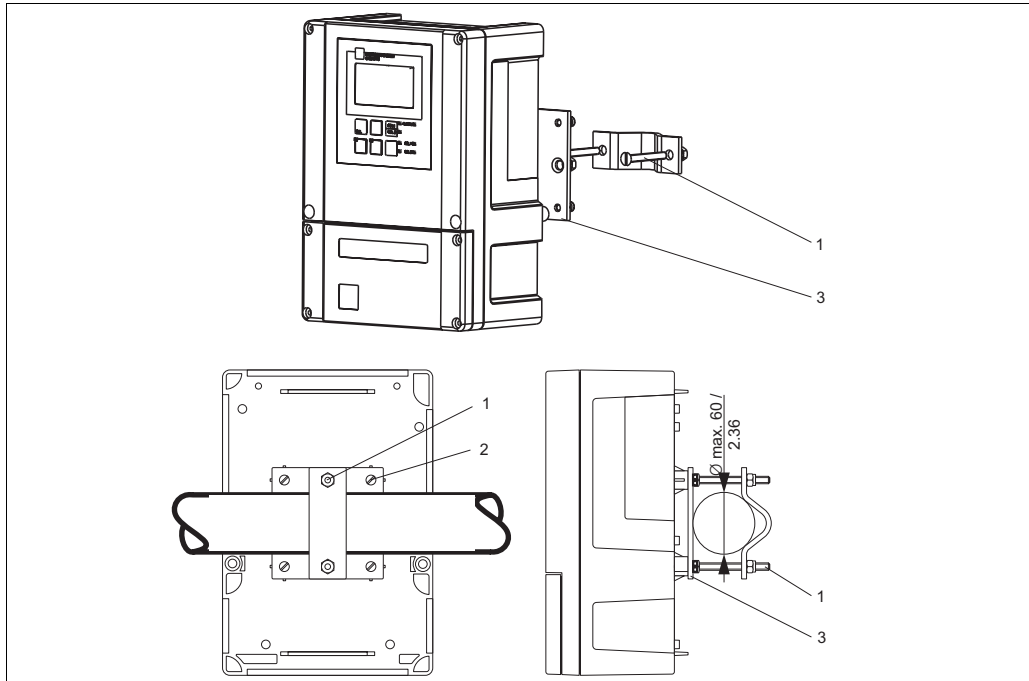
1. Drill the bores as shown in Fig. 5 .
2. Drive the two fixing screws through the securing bores (1) from the front.
3. Mount the transmitter on the wall as shown.
4. Cover the bores with plastic caps (2).

Transmitter post mounting



Note!

You require a post mounting kit to secure the field device to horizontal and vertical posts or pipes (max. \varnothing 60 mm (2.36")). This can be acquired as an accessory (see "Accessories" section).



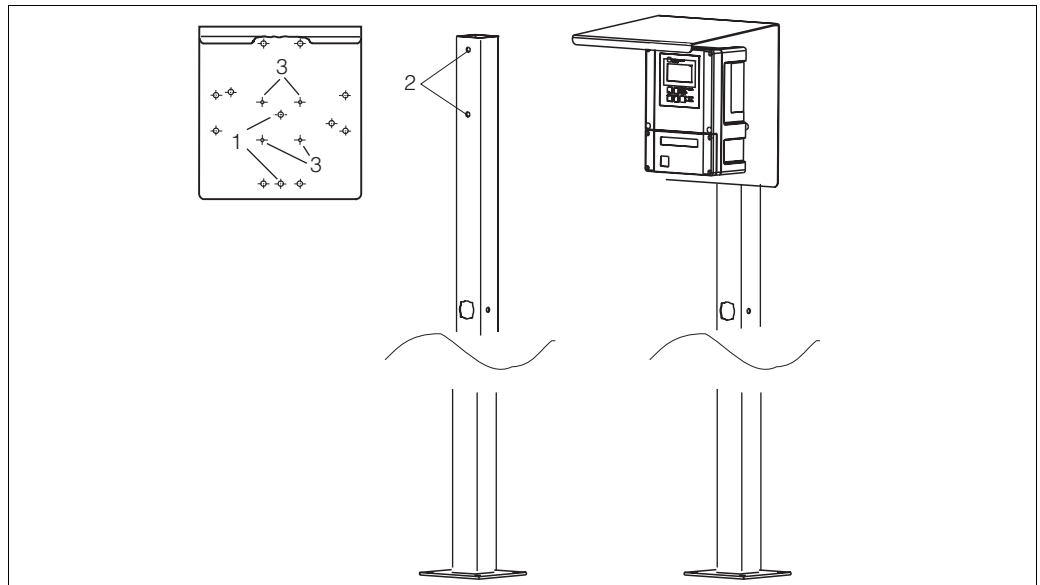
C07-0xM253xx-11-06-00-en-003.eps

Fig. 6: Post mounting field device to cylindrical pipes

For post mounting the transmitter, proceed as follows:

1. Guide the two securing screws (1) of the mounting kit through the openings of the securing plate (3).
2. Screw the securing plate onto the transmitter using the four fixing screws (2).
3. Secure the retainer with the field device using the clip on the post or pipe.

You can also secure the field device to a square universal post in conjunction with the weather protection cover. These can be acquired as accessories, see "Accessories" section.



C07-0xM253xx-11-06-00-xx-004.eps

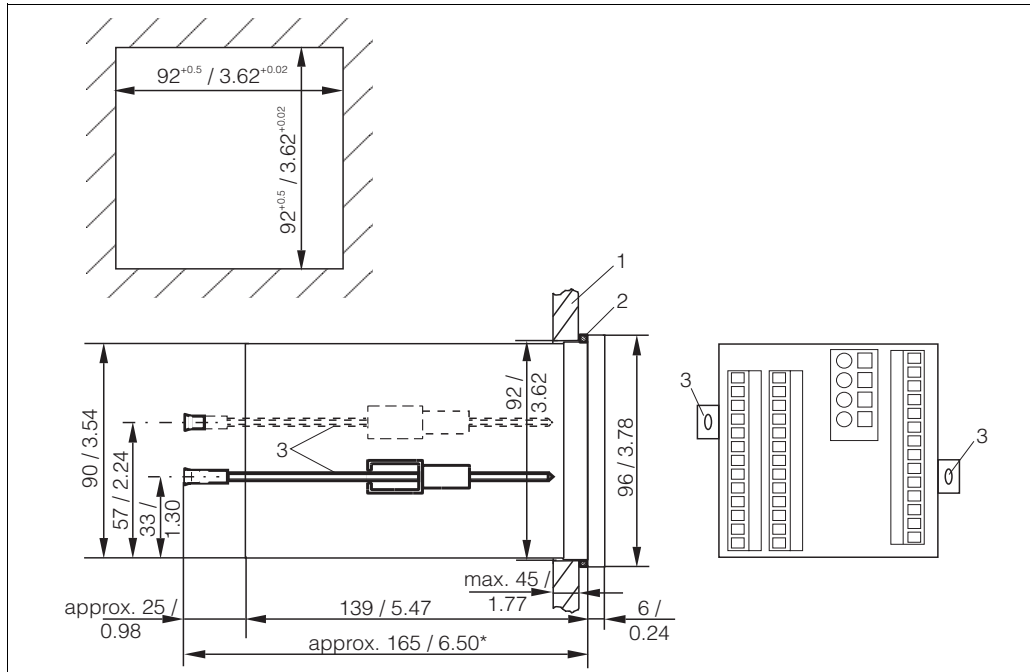
Fig. 7: Mounting field device with universal posts and weather protection cover

For mounting the weather protection cover, proceed as follows:

1. Screw the weather protection cover with 2 screws (bores 1) to the upright post (bores 2).
2. Secure the field device to the weather protection cover. To do so, use the bores (3).

3.4.2 Panel-mounted instrument

The panel-mounted instrument is secured with the clamping screws supplied (see Fig. 8). The necessary installation depth is approx. 165 mm (6.50").



C07-0xM223xx-11-06-00-en-001.eps

Fig. 8: Securing the panel-mounted instrument

- 1 Wall of the cabinet
- 2 Seal
- 3 Clamping screws
- * Required installation depth

3.5 Post-installation check

- After installation, check the transmitter for damage.
- Check whether the transmitter is protected against moisture and direct sunlight.

4 Wiring

4.1 Electrical connection



Warning!

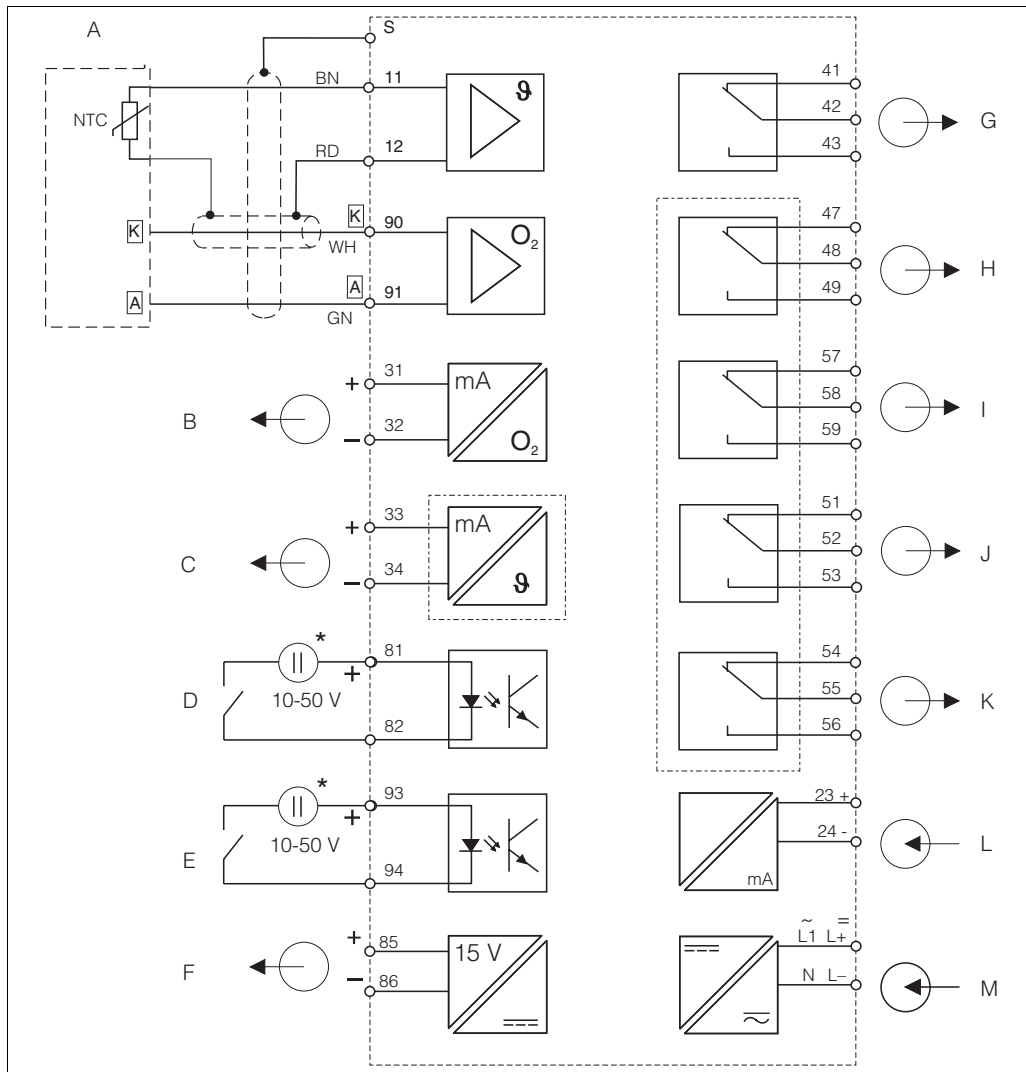
- The electrical connection must only be carried out by authorised technical personnel.
- Technical personnel must have read and understood the instructions in this manual and must adhere to them.
- Ensure that there is no voltage at the power cable before beginning the connection work.

The electrical connection of the transmitter differs depending on the device version:

- If you are using the device version DX/DS (with OOS41), please read the instructions in the "Electrical connection variant 1" section.
- If you are using the device version WX/WS (with OOS31, OOS61 or OOS71), please read the instructions in the "Electrical connection variant 2" section.

4.1.1 Electrical connection variant 1 (DX/DS with OOS41)

The wiring diagram depicted in Fig. 9 shows the connections of the transmitter with all the options.



C07-OOM2x3xx-04-06-00-xx-001.eps

Fig. 9: Electrical connection of the transmitter in version DX or DS

- | | | | |
|---|--|---|---|
| A | Oxygen sensor OOS41 | G | Alarm (current-free contact position) |
| B | Signal output 1 oxygen | H | Relay 1 (current-free contact position) |
| C | Signal output 2 temperature/controller | I | Relay 2 (current-free contact position) |
| D | Binary input 1 (Hold) | J | Relay 3 (current-free contact position) |
| E | Binary input 2 (Chemoclean) | K | Relay 4 (current-free contact position) |
| F | Aux. voltage output | L | Current input 4 ... 20 mA |
| | | M | Power supply |

* Aux. voltage output terminal 85/86 applicable



Note!

The device is approved for protection class II and is generally operated without a protective earth connection.

The circuits "C" and "F" are not galvanically isolated from each other.

Field instrument connection version DX/DS

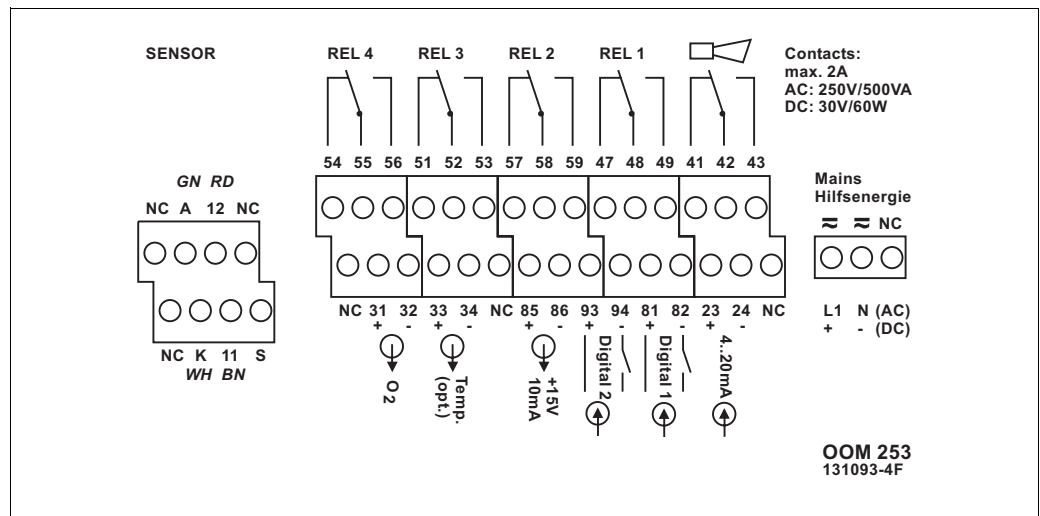
To connect the field instrument proceed as follows:

1. Open the front cover to get access to the terminals.
2. Cut out the marked PG gland hole of the housing. Mount a PG gland and guide the measuring cable through the PG gland into the housing.
3. Connect the measuring cable in accordance with the connection diagram.
4. Fix the PG gland.



Caution!

- Always protect plugs, terminals and cables against humidity.
- Terminals marked NC may not be wired.
- Unmarked terminals may not be wired.



C07-OOM253xx-04-06-00-xx-002.eps

Fig. 10: Field instrument connection compartment sticker

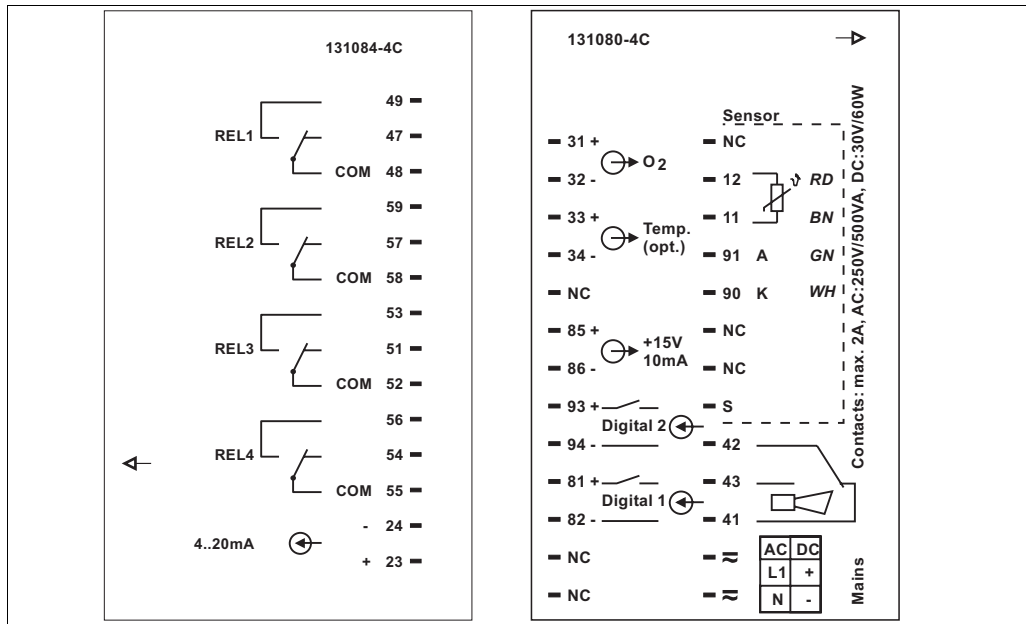


Note!

Please label the sensor terminal block with the sticker provided.

Panel-mounted instrument connection

Connect the cables in accordance with the connection diagram.



C07-00M223xx-04-06-00-xx-001.eps

Fig. 11: Panel mounted instrument connection sticker



Caution!

- Terminals marked NC may not be wired.
- Unmarked terminals may not be wired.

4.1.2 Measuring cable and sensor connection

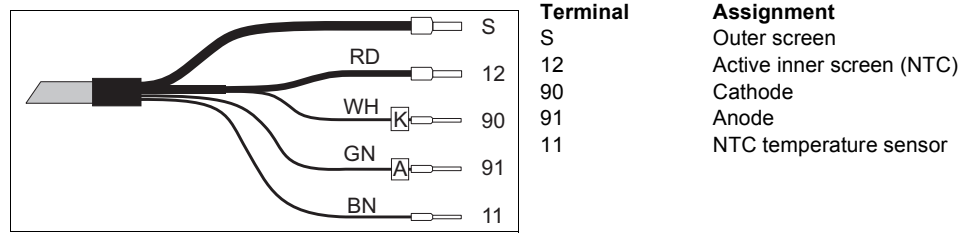
You require screened special measuring cables to connect oxygen sensor OOS41 to the transmitter. To extend the measuring cable, use junction box and extension cable:

Sensor	Sensor cable	Extension
OOS41	OYK71	VBM junction box + OYK71 cable

You can also use measuring cable CMK.

Maximum cable length	
OOS41	50 m (164 ft) with CMK / OYK71 cable

Structure of the measuring cable



C07-OOS41xxx-04-05-00-xx-001.eps

Fig. 12: Measuring cable CMK or OYK71

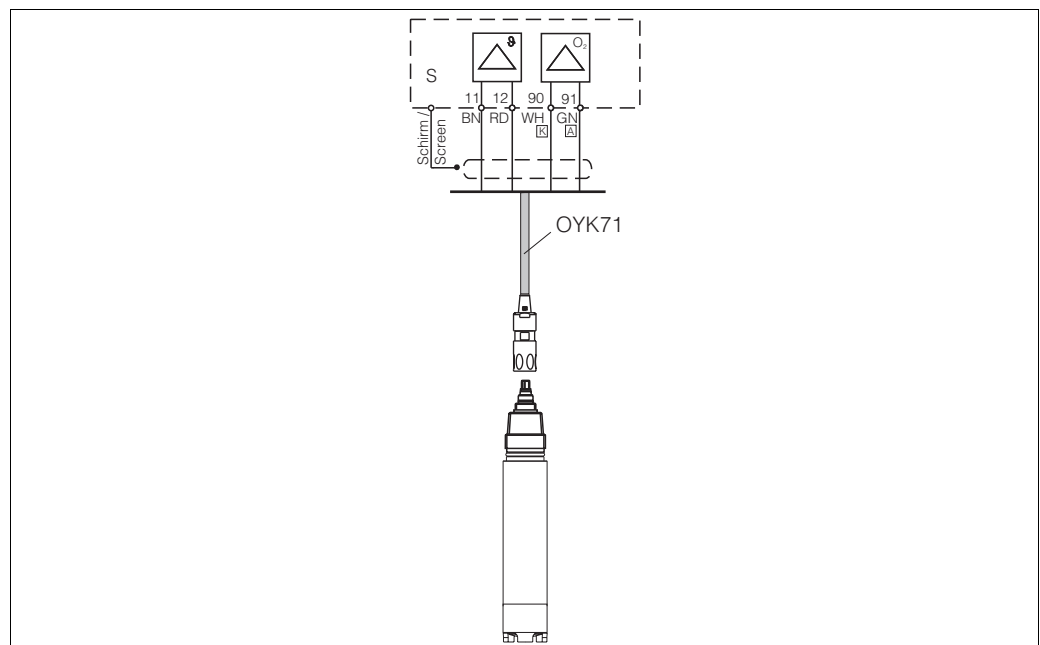


Note!

For further information on cables and junction boxes refer to chapter "Accessories".

Example of connecting an oxygen sensor

Connection of the oxygen sensor OOS41:

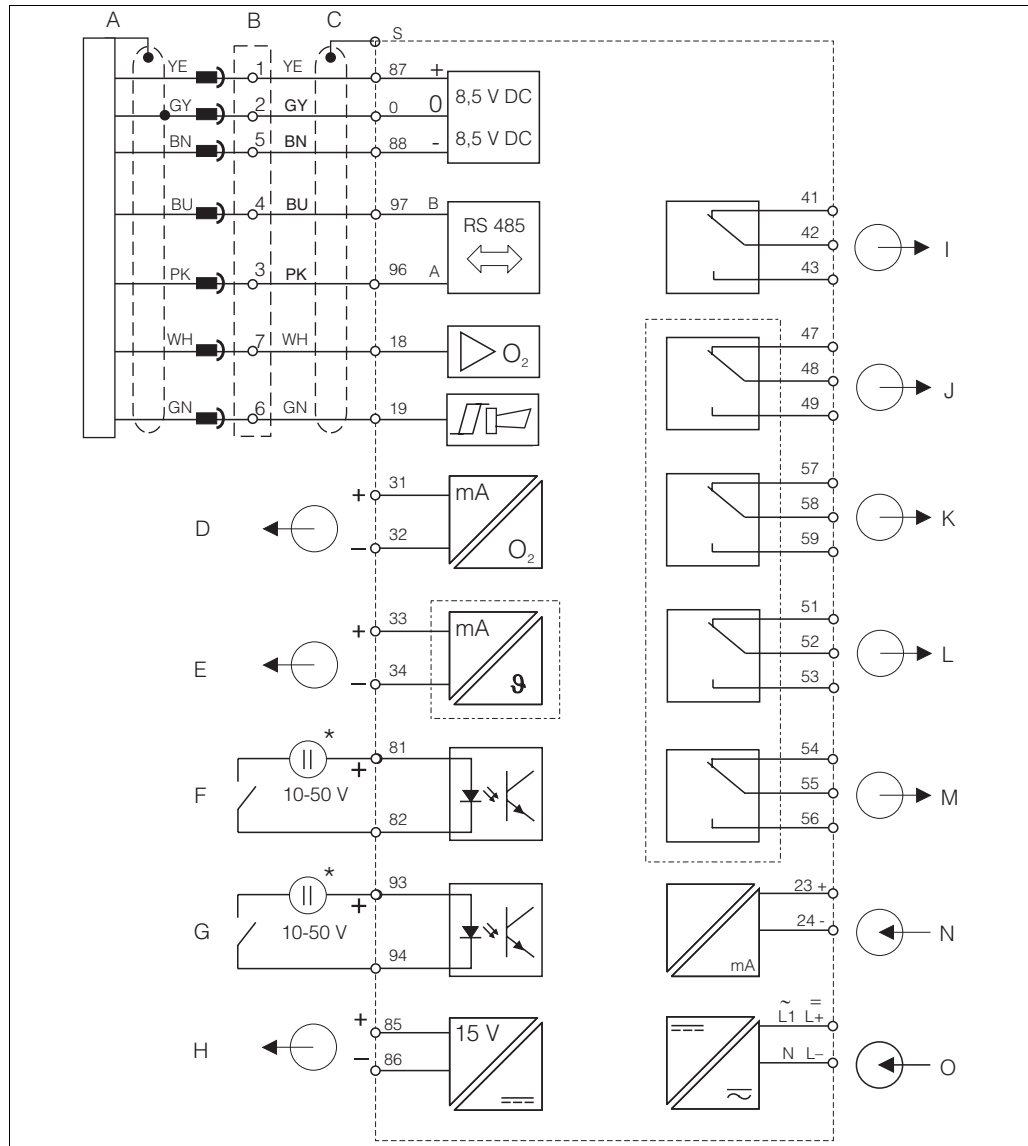


C07-OOM2x3xx-04-06-00-xx-002.eps

Fig. 13: Connection of OOS41 with OYK71 cable

4.1.3 Electrical connection variant 2 (WX/WS with OOS31/71 or OOS61 with serial number 79xxxx or later)

The wiring diagram depicted in Fig. 14 shows the connections of the transmitter with all the options.



C07-OOM2x3xx-04-06-00-xx-003.eps

Fig. 14: Electrical connection of the transmitter version WX or WS

A	Oxygen sensor OOS31/61/71	H	Aux. voltage output
B	Junction box VS with extension	I	Alarm (current-free contact position)
C	OOM253: Plug connection for oxygen sensor OOM223: the sensor cable plug must be removed or junction box VS used	J	Relay 1 (current-free contact position)
D	Signal output 1 oxygen	K	Relay 2 (current-free contact position)
E	Signal output 2 temperature/controller	L	Relay 3 (current-free contact position)
F	Binary input 1 (Hold)	M	Relay 4 (current-free contact position)
G	Binary input 2 (Chemoclean)	N	Current input 4 ... 20 mA
		O	Power supply

* Aux. voltage output terminal 85/86 applicable

Note!

The device is approved for protection class II and is generally operated without a protective earth connection.

The circuits "E" and "H" are not galvanically isolated from each other.

The signals "Sensor signal" (18) and "Alarm" (19) are not used at the TOP68 version.



Field instrument connection

For connection, the measuring cables are introduced through the cable glands on the field instrument and connected according to the following diagram. The sensor is plugged in from the outside (7-pin socket SXB).

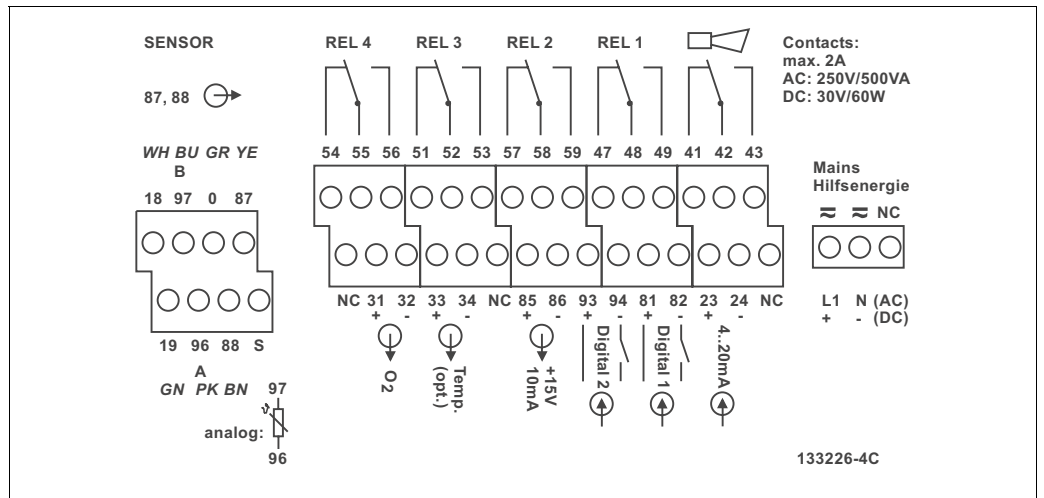


Fig. 15: Field instrument connection compartment sticker version WX/WS

C07-00M253xx-04-06-00-xx-003.eps



Caution!

- Terminals marked NC may not be wired.
- Unmarked terminals may not be wired.

Note!

Please label the sensor terminal block with the sticker provided.

Panel-mounted instrument connection

To connect a sensor to the panel mounted instrument you have to take off the sensor plug. Connect the cable conductors directly to the terminals of the transmitter. If you need a pluggable connection you can install a VS junction box between sensor and transmitter.

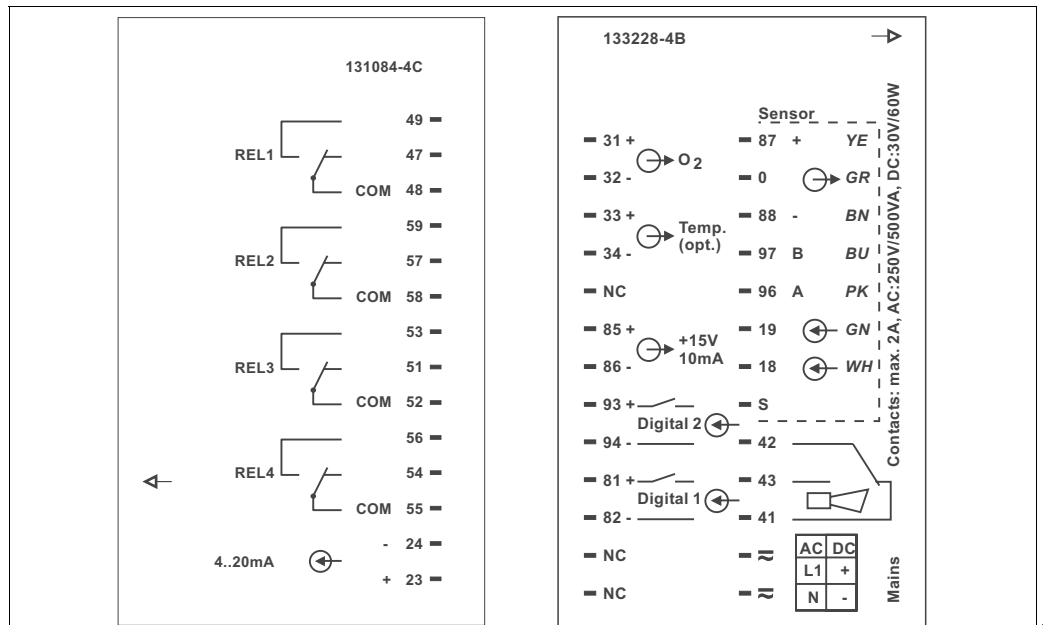


Fig. 16: Panel mounted instrument connection sticker

C07-00M223xx-04-06-00-xx-002.eps



Caution!

- Terminals marked NC may not be wired.
- Unmarked terminals may not be wired.

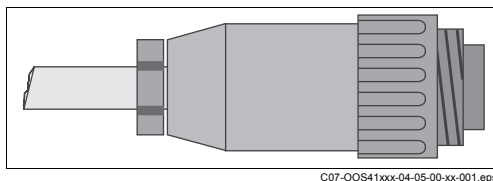
4.1.4 Measuring cable and sensor connection

To extend the measuring cable you require a junction box and an extension cable:

Sensor	Sensor cable	Extension
OOS31/61/71 with fixed cable connection	OMK with SXP plug	VS junction box + OMK cable
OOS31/61/71 with TOP68 connection	OYK71 with SXP plug	VS junction box + OMK cable

Maximum cable length	
OOS31/61/71	100 m (328 ft) with OMK / OYK71 cable

Pin assignment of the SXP plug with OMK cable



	OMK		OYK
1 yellow	+UB	+UB	yellow
2 grey	0 V	0 V	white
3 pink	RS 485 (NTC)	RS 485 (NTC)	green
4 blue	RS 485 (NTC)	RS 485 (NTC)	brown
5 brown	-UB	-UB	coax inner
6 green	Alarm	NC	
7 white	Sensor signal	NC	

Fig. 17: Sensor plug with special measuring cable OMK



Note!

For further information on cables and junction boxes refer to chapter "Accessories".

Example of connecting an oxygen sensor

Connection of the oxygen sensor OOS31/61/71.

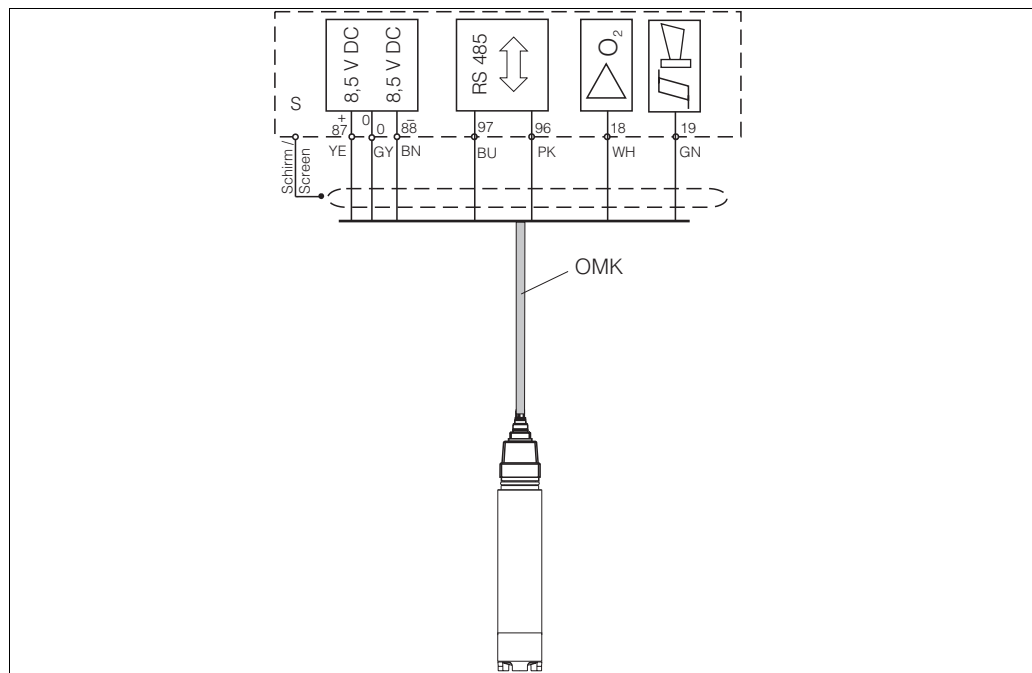


Fig. 18: Connection of OOS31/71 with OMK cable

C07-OOM2x3xx-04-06-00-xx-005.eps

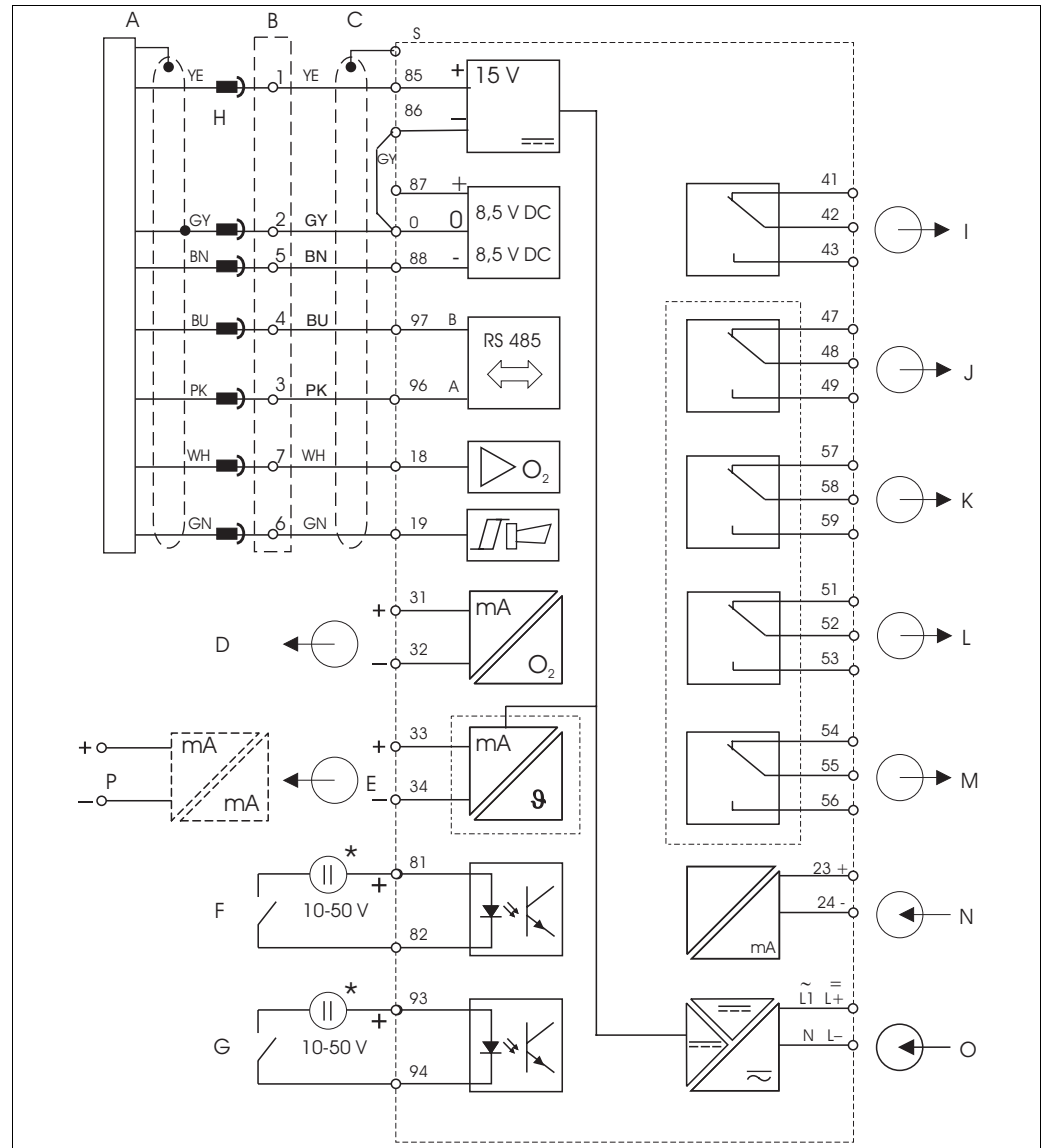


Note!

The signals **Sensor signal** and **Alarm** are not used by OOS61 and the TOP68-versions.

4.1.5 Electrical connection variant 2 (WX/WS with OOS61 up to serial number 78xxxx)

The wiring diagram depicted in Fig. 19 shows the connections of the transmitter with all the options for the sensor OOS61.



C07-OOM2x3xx-04-06-00-xx-006.eps

Fig. 19: Electrical connection of the transmitter version WX or WS for OOS61

- | | | | |
|---|---|---|---|
| A | Oxygen sensor OOS61 | H | Aux. voltage output |
| B | Junction box VS with extension | I | Alarm (current-free contact position) |
| C | OOM253: Plug connection for oxygen sensor
OOM223: the sensor cable plug must be
removed or junction box VS used | J | Relay 1 (current-free contact position) |
| D | Signal output 1 oxygen | K | Relay 2 (current-free contact position) |
| E | Signal output 2 temperature/controller | L | Relay 3 (current-free contact position) |
| F | Binary input 1 (Hold) | M | Relay 4 (current-free contact position) |
| G | Binary input 2 (Chemoclean) | N | Current input 4 ... 20 mA |
| | | O | Power supply |
| | | P | Isolation converter |

* Aux. voltage output terminal 85/86 applicable



Note!

The device is approved for protection class II and is generally operated without a protective ground connection.

The circuits "E" and "H" are not galvanically isolated from each other.

The signals "Sensor signal" (18) and "Alarm" (19) are not used at the TOP68 version.

Sensor OOS61 uses the aux. voltage 15 V. This eliminates the galvanic isolation to the signal output 2.

To connect both signal outputs to a process control system, the inputs of the process control system must be galvanically isolated. If the inputs are not galvanically isolated, you can connect "signal output 2" via an isolation converter (0/4 - 20 mA / 0/4 - 20 mA) to the input of the process control system.

Field instrument connection

Plug the sensor plug into the SXB socket. Additionally you have to modify the terminal wiring:

- Remove the yellow wire (from SXB socket pin 1) from terminal 87 and connect it to terminal 85.
- Terminal 87 will not be connected.
- Connect an additional wire from terminal 86 to terminal 0.

Introduce all other cables through the cable glands and connect them according to the connection diagram.

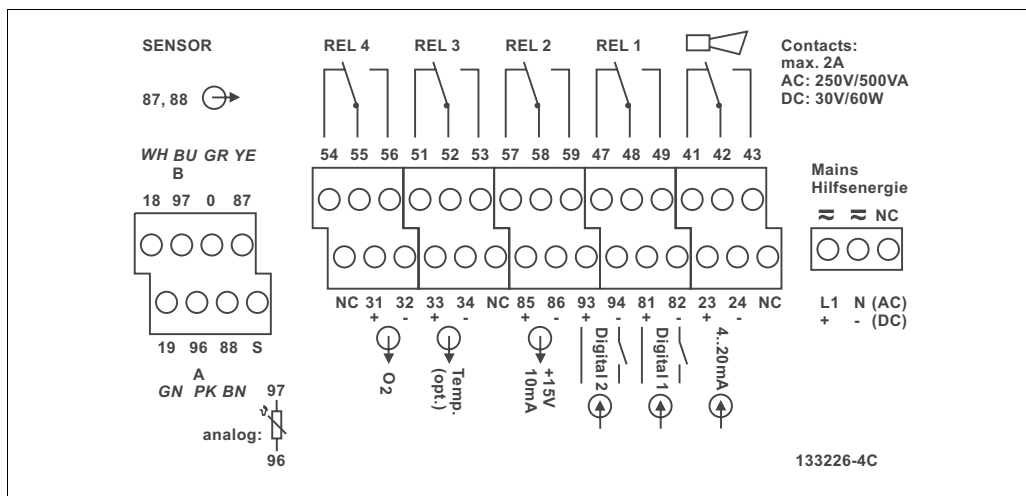


Fig. 20: Field instrument connection compartment sticker version WX/WS



Note!

Please label the sensor terminal block with the sticker provided.

Panel-mounted instrument connection

To connect a sensor to the panel-mounted instrument, you have to take off the sensor plug. Connect the cable wires directly to the terminals of the transmitter. If you need a pluggable connection, you can install a VS junction box between sensor and transmitter.

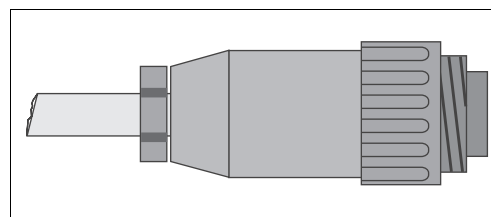
4.1.6 Measuring cable and sensor connection

To extend the measuring cable you require a junction box and an extension cable:

Sensor	Sensor cable	Extension
OOS31/61/71 with fixed cable connection	OMK with SXP plug	VS junction box + OMK cable
OOS31/61/71 with TOP68 connection	OYK71 with SXP plug	VS junction box + OMK cable

Maximum cable length	
OOS31/61/71	100 m (328 ft) with OMK / OYK71 cable

Pin assignment of the SXP plug with OMK cable



	OMK		CYK
1 yellow	+UB	+UB	yellow
2 grey	0 V	0 V	white
3 pink	RS 485 (NTC)	RS 485 (NTC)	green
4 blue	RS 485 (NTC)	RS 485 (NTC)	brown
5 brown	-UB	-UB	coax inner
6 green	Alarm	NC	
7 white	Sensor signal	NC	

Fig. 21: Sensor plug with special measuring cable OMK

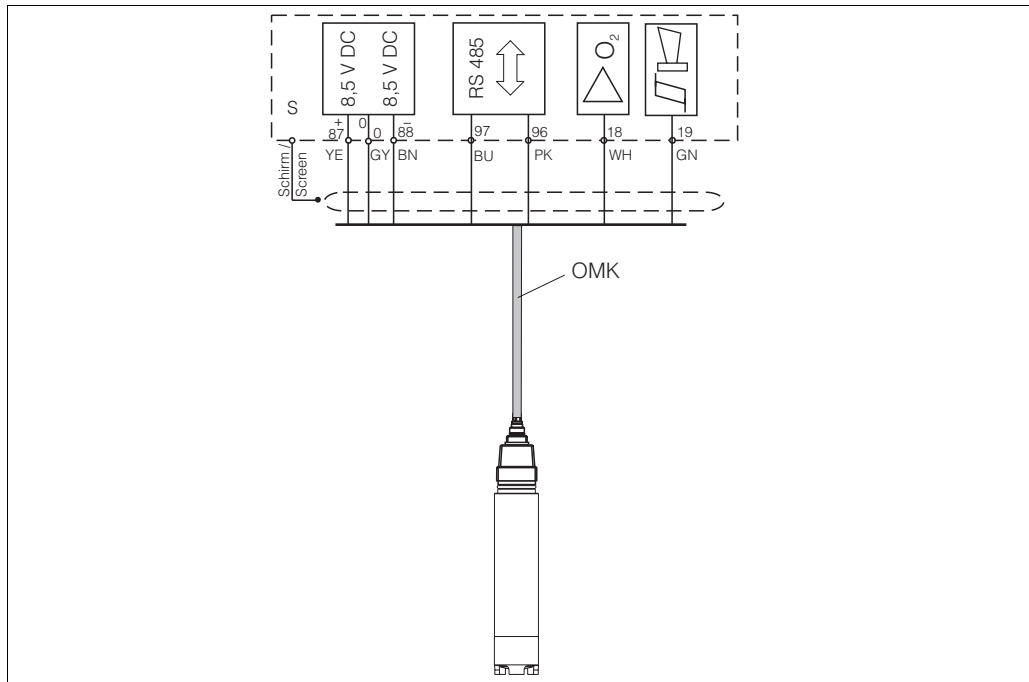


Note!

For further information on cables and junction boxes refer to chapter "Accessories".

Example of connecting an oxygen sensor

Connection of the oxygen sensor OOS61.



C07-OOM2x3xx-04-06-00-xx-005.eps

Fig. 22: Connection of OOS61 with OMK cable



Note!

The signals **Sensor signal** (18) and **Alarm** (19) are not used by OOS61 and the TOP68 versions.

Panel-mounted instrument connection

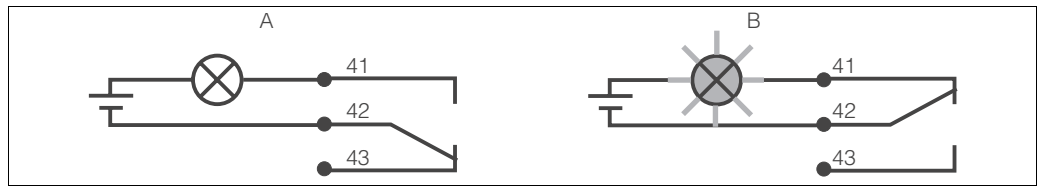
Connect the sensor according to the connection diagram.

Field instrument connection

Plug the sensor plug into the SXB socket. Additionally you have to modify the terminal wiring:

- Remove the yellow wire (from SXB socket pin 1) from terminal 87 and connect it to terminal 85.
- Terminal 87 will not be connected.
- Connect an additional wire from terminal 86 to terminal 0.

4.1.7 Alarm contact



C07-OxM2x3xx-04-06-00-xx-001.eps

Fig. 23: Recommended fail-safe switching for the alarm contact

A Normal operating status

B Alarm condition

Normal operating status:

- Device in operation
- No error message present (Alarm LED off)

- › Relay energised
- › Contact 42/43 closed

Alarm condition

- Error message present (alarm LED red) or
- Device defective or voltage-free (alarm LED off)

- › Relay de-energised
- › Contact 41/42 closed

4.2 Post-connection check

After the electrical connection, carry out the following checks:

Device condition and specifications	Notes
Are the transmitter and cables damaged on the outside?	Visual inspection

Electrical connection	Notes
Are the mounted cables strain relieved?	
Cable run without loops and cross-overs?	
Are the signal lines correctly connected in accordance with the wiring diagram?	
Are all the screw terminals tightened?	
Are all the cable entries installed, tightened and sealed?	

5 Operation

5.1 Quick operation guide

You have the following ways of operating the transmitter:

- On site via the key field
- Via the HART® interface (optional, with corresponding order version) per:
 - HART® handheld terminal or
 - PC with HART® modem and the Commuwin II software package
- Via PROFIBUS PA/DP (optional, with corresponding order version) with:
 - PC with corresponding interface and the Commuwin II software package (see Accessories)
 - or via a programmable logic controller (PLC)



Note!

For operation via HART or PROFIBUS PA/DP, please read the relevant sections in the additional Operating Instructions:



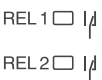

- PROFIBUS PA/DP, field communication for OXM223/253, BA209e00
- HART®, field communication for OXM223/253, BA208e00

The following section only explains operation via the keys.

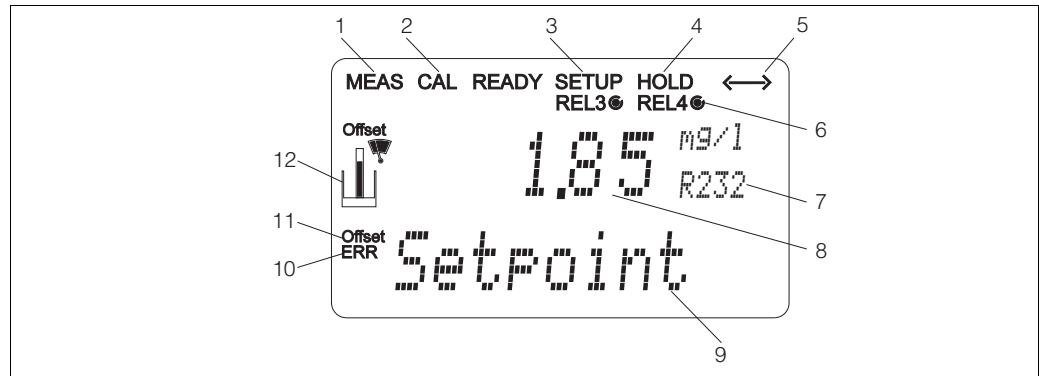
5.2 Display and operating elements

5.2.1 Display

LED display

	Indicates the current operating mode, "Auto" (green LED) or "Manual" (yellow LED)
	Indicates the activated relay in the "Manual" mode (red LED)
	Indicates the working status of relay 1 and 2 LED green: measured value within the permitted limit, relay inactive LED red: measured value outside the permitted limit, relay active
	Alarm display, e.g. for continuous limit value overshoot, temperature sensor failure or system error (see error list)

LC display

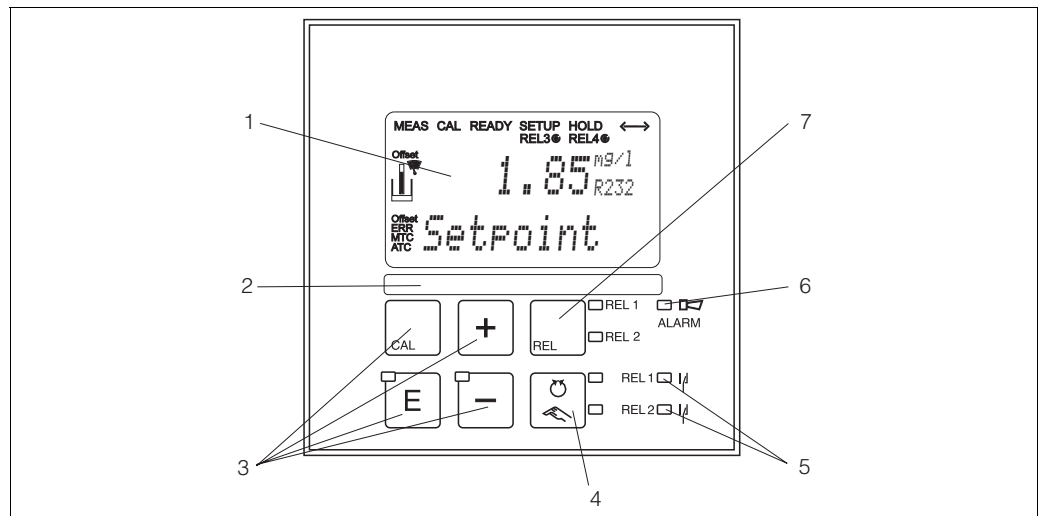


C07-00M2x3xx-07-06-00-en-001.eps

Fig. 24: LC display transmitter

- | | | | |
|---|--|----|--|
| 1 | Indicator for measuring mode (normal operation) | 7 | Function code display |
| 2 | Indicator for calibration mode | 8 | In measuring mode: measured variable
In setup mode: configured variable |
| 3 | Indicator for setup mode (configuration) | 9 | In measuring mode: secondary measured value
In setup/calibr. mode: e.g. setting value |
| 4 | Indicator for "Hold" mode (current outputs remain at last current state) | 10 | "Error": error display |
| 5 | Indicator for receipt of a message for devices with communication | 11 | Temperature offset |
| 6 | Indicator of working status of relays 3/4:
C inactive, ● active | 12 | Sensor symbol |

5.2.2 Operating elements










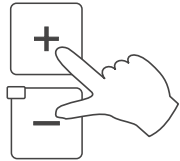
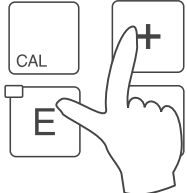

C07-00M2x3xx-19-06-00-en-001.eps

Fig. 25: Operating elements

- | | |
|---|---|
| 1 | LC display for displaying the measured values and configuration data |
| 2 | Field for user labelling |
| 3 | Changeover switch for calibration and device configuration |
| 4 | Changeover switch for automatic/manual mode of the relays |
| 5 | LEDs for limit contactor relay (switch status) |
| 6 | LED for alarm function |
| 7 | Display of the active contact and key for relay changeover in manual mode |

5.2.3 Key assignment

	<p>CAL key When you press the CAL key, the device first prompts you for the calibration access code:</p> <ul style="list-style-type: none"> • Code 22 for calibration • Code 0 or any other code for reading the last calibration data <p>Use the CAL key to accept the calibration data or to switch from field to field within the calibration menu.</p>
	<p>ENTER key When you press the ENTER key, the device first prompts you for the setup mode access code:</p> <ul style="list-style-type: none"> • Code 22 for setup and configuration • Code 0 or any other code for reading all configuration data. <p>The ENTER key has several functions:</p> <ul style="list-style-type: none"> • Calls up the Setup menu from the measuring mode. • Saves (confirms) data entered in the setup mode. • Moves on within function groups.
 	<p>PLUS key and MINUS key In the setup mode, the PLUS and MINUS keys have the following functions:</p> <ul style="list-style-type: none"> • Selection of function groups. <p> Note! Press the MINUS key to select the function groups in the order given in the "System configuration" section.</p> <ul style="list-style-type: none"> • Configuration of parameters and numerical values • Operation of the relay in manual mode <p>In the measuring mode, you get the following sequence of functions by repeatedly pressing the PLUS key:</p> <ol style="list-style-type: none"> 1. Temperature display in F 2. Temperature display hidden 3. Measured value display in mg/l 4. Measured value display in %SAT 5. Measured value display in hPa 6. Sensor current in nA/mA 7. Current input signal in % 8. Current input signal in mA 9. Return to basic settings <p>In the measuring mode, the following is displayed in sequence by repeatedly pressing the MINUS key:</p> <ol style="list-style-type: none"> 1. Current errors are displayed in rotation (max. 10). 2. Once all the errors have been displayed, the standard measurement display appears. In the function group F, an alarm can be defined separately for each error code.



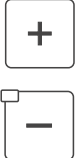

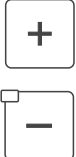

	<p>REL key In the manual mode, you can use the REL key to switch between the relay and the manual start of cleaning. In the automatic mode, you can use the REL key to read out the switch-on points (for limit contactor) or set points (for PID controller) assigned to the relay in question. Press the PLUS key to jump to the settings of the next relay. Use the REL key to get back to the display mode (automatic return after 30 s).</p>
	<p>AUTO key You can use the AUTO key to switch between automatic mode and manual mode.</p>
	<p>Escape function If you press the PLUS and MINUS key simultaneously, you return to the main menu or are taken to the end of calibration if calibrating. If you press the PLUS and MINUS key again, you return to the measuring mode.</p>
	<p>Locking the keyboard Press the PLUS and ENTER key for at least 3 s to lock the keyboard against any unauthorised data entry. All the settings can continue to be read. The code prompt displays the code 9999.</p>
	<p>Unlocking the keyboard Press the CAL and MINUS key for at least 3 s to unlock the keyboard. The code prompt displays the code 0.</p>

5.3 Local Operation

5.3.1 Automatic/manual mode

The transmitter normally operates in automatic mode. Here, the relays are triggered by the transmitter. In the manual mode, you can trigger the relays using the REL key or start the cleaning function.

How to change the operating mode:

	<p>1. The transmitter is in Automatic mode. The top LED beside the AUTO key is lit.</p>
	<p>2. Press the AUTO key. The bottom LED beside the AUTO key lights up.</p>
	<p>3. To enable the manual mode, enter the code 22 via the PLUS and MINUS keys.</p>
	<p>4. Select the relay or the function. You can use the REL key to switch between the relays. The relay selected and the switch status (ON/OFF) is displayed on the second line of the display. In the manual mode, the measured value is displayed continuously (e.g. for measured value monitoring for dosing functions).</p>
	<p>5. Switch the relay. It is switched on with PLUS and switched off with MINUS. The relay remains in its switched state until it is switched over again.</p>
	<p>6. Press the AUTO key to return to the measuring mode, i.e. to the automatic mode. All the relays are triggered again by the transmitter.</p>

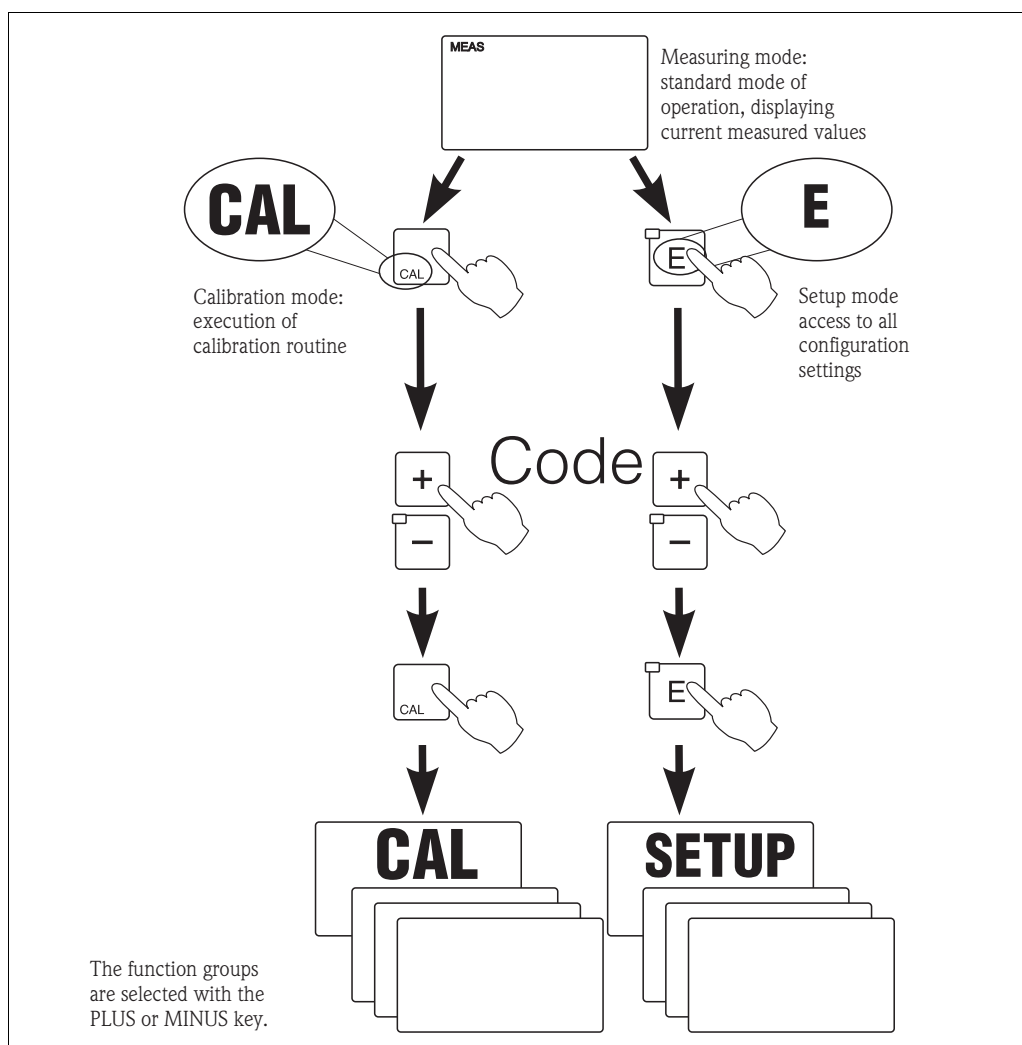


Note!

- The operating mode remains in effect even after a power failure.
- The manual mode has priority over all other automatic functions (Hold).
- Hardware locking is not possible in the manual mode.
- The manual settings are kept until they are actively reset.
- Error code E102 is signalled in the manual mode.

5.3.2 Operating concept

Operating modes



C07-0xM2x3xx-19-06-00-en-001.eps

Fig. 26: Description of the possible operating modes



Note!

If no key is pressed in the setup mode for approx. 15 min, the device automatically returns to the measuring mode. Any active Hold (Hold during setup) is reset.

Access codes

All device access codes are fixed and cannot be altered. When the device requests the access code, it distinguishes between different codes.

- **Key CAL + Code 22:** access to Calibration and Offset menu
- **Key ENTER + Code 22:** access to the menus for the parameters which make configuration and user-specific settings possible
- **Keys PLUS + ENTER:** locks the keyboard
- **Keys CAL + MINUS:** unlocks the keyboard
- **Key CAL or ENTER + any code:** access to read mode, i.e. all the settings can be read but not modified.

The device continues measuring in the read mode. It does not shift to the Hold status. The current output and the controllers remain active.

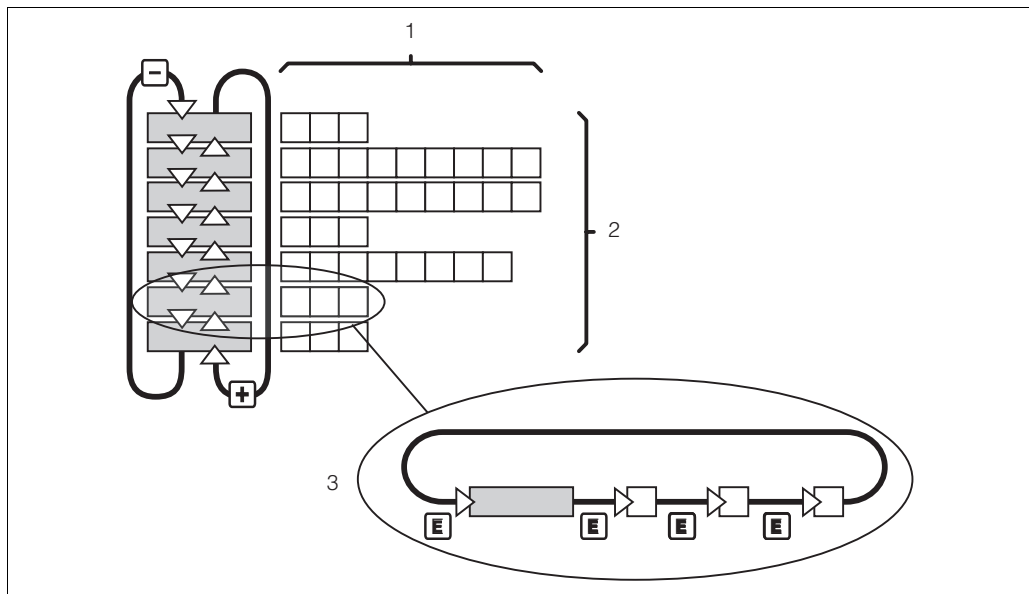
Menu structure

The configuration and calibration functions are arranged in function groups.

- In the setup mode, select a function group with the PLUS and MINUS keys.
- In the function group itself, switch from function to function with the ENTER key.
- Within the function, select the desired option with the PLUS and MINUS keys or edit the settings with these keys. Then confirm with the ENTER key and continue.
- Press the PLUS and MINUS keys simultaneously (Escape function) to exit programming (return to the main menu).
- Press the PLUS and MINUS simultaneously keys again to switch to the measuring mode.

Note!

- If a modified setting is not confirmed with ENTER, the old setting is retained.
- An overview of the menu structure is provided in the Appendix to these Operating Instructions.



C07-0xM2x3xx-19-06-00-xx-002.eps

Fig. 27: Diagram of the menu structure

- 1 Functions (parameters selected, numbers entered)
- 2 Function groups, scroll backwards and forwards with the PLUS and MINUS keys
- 3 Switch from function to function with the ENTER key

Hold function: "freezing" of the outputs

In both the setup mode and during calibration, the current output can be "frozen", it constantly retains its current status. "HOLD" appears on the display. If the controller actuating variable (steady control 4 ... 20 mA) is output via current output 2, it is set to 0/4 mA in Hold.

Note!

- Hold settings can be found in the "Service" section.
- During Hold, all contacts will go to their normal positions.
- An active Hold has priority over all other functions.
- With every Hold, the I-component of the controller is set to zero.
- Any alarm delay is reset to "0".
- This function can also be activated externally via the Hold input (see Wiring diagram; binary input 1).
- The manual Hold (field S3) remains active even after a power failure.

6 Commissioning

6.1 Function check



Warning!

- Check all connections for correctness.
- Make sure that the supply voltage is identical to the voltage written on the nameplate!

6.2 Switching on

Familiarise yourself with the operation of the transmitter before it is first switched on. Please refer in particular to the "Safety instructions" and "Operation" sections.

After power-up, the device performs a self-test and then goes to the measuring mode.

Now calibrate the sensor in accordance with the instructions in the "Calibration" section.



Note!

During commissioning, the sensor must be calibrated so that the measuring system can return precise measurement data.

Then perform the first configuration in accordance with the instructions in the "Quick start-up" section. The values set by the user are kept even in the event of a power failure.

The following function groups are available in the transmitter (the groups only available in the Plus Package are marked accordingly in the functional description):

Setup mode

- SETUP 1 (A)
- SETUP 2 (B)
- CURRENT INPUT (Z)
- CURRENT OUTPUT (O)
- ALARM (F)
- CHECK (P)
- RELAY (R)
- SERVICE (S)
- SERVICE 2 (E)
- INTERFACE (I)

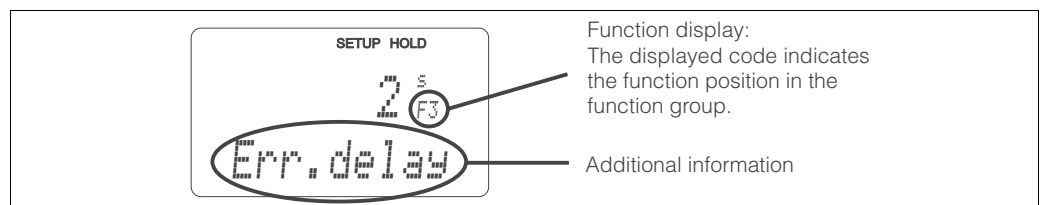
Calibration and offset mode

- CALIBRATION (C)



Note!

A detailed explanation of the function groups available in the transmitter can be found in the "System configuration" section.



C07-OLD132xx-07-06-00-en-003.eps

Fig. 28: Example for display in setup mode

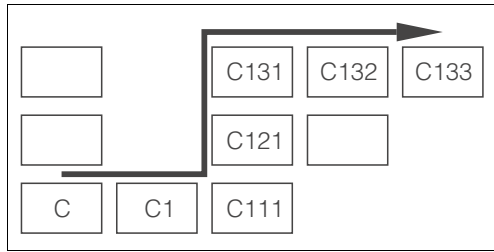


Fig. 29: Function coding

Selecting and locating functions is facilitated by a code displayed for each function in a special display field Fig. 28. The structure of this coding is given in Fig. 29.

The first column indicates the function group as a letter (see group designations). The functions in the individual groups are counted from the top to the bottom and from the left to the right.

Factory settings

The first time it is switched on, the device has the factory setting for all functions. The table below provides an overview of the most important settings.

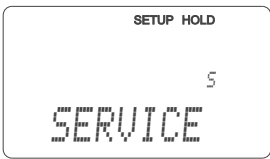
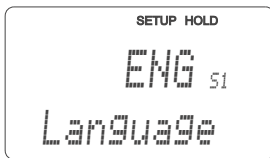
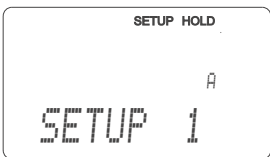
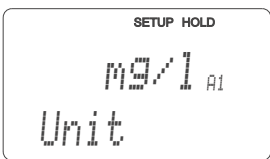
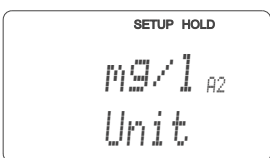
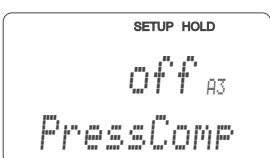
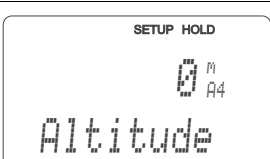
All other factory settings can be found in the description of the individual function groups in the "System configuration" section (the factory setting is highlighted in **bold**).

Function	Factory setting
Type of measurement	Oxygen concentration in mg/l Temperature in °C
Automatic pressure compensation*	Off (only with version WX/WS/DS)
Altitude	0 m above sea level
Salinity	0.0 % salt concentration
Current outputs 1* and 2*	4 ... 20 mA
Current output 1: measured value for 4 mA signal current*	0.00 mg/l 0.000 mg/l (only with sensor OOS71)
Current output 1: measured value for 20 mA signal current*	10.00 mg/l 10.000 mg/l (only with sensor OOS71)
Current output 2: temperature value for 4 mA signal current*	0.0 C (32 °F)
Current output 2: temperature value for 20 mA signal current*	40.0 C (104 °F)
Alarm contact	Latching contact
Alarm delay	Setting in minutes
Error current for alarm	22 mA
Check functions*	Off. Can be switched on as required.
Setpoint for oxygen	5.00 mg/l 5.000 mg/l (only with sensor OOS71)
Language	English

* For corresponding version

6.3 Quick start-up

After power-up, you must make some settings to configure the most important functions of the transmitter which are required for correct measurement. The following section gives an example of this.

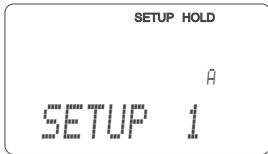
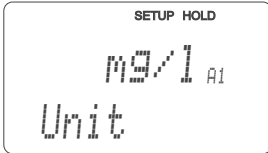

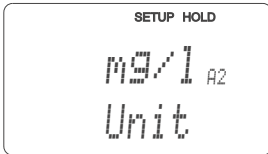

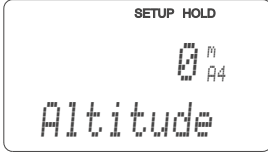
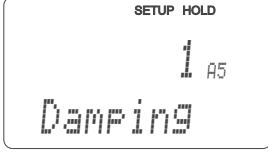
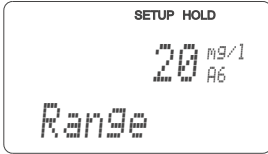
User input	Setting range (Factory settings, bold)	Display
1. Press the E key. 2. Enter the code 22 to edit the setup. Press E .		
3. Press - until you get to the "Service" function group. 4. Press E to be able to make your settings.		 <p>SETUP HOLD 5 SERVICE</p>
5. In S1, select your language, e.g. "ENG" for English. Press E to confirm.	ENG = English GER = German FRA = French ITA = Italian NEL = Dutch ESP = Spanish	 <p>SETUP HOLD ENG S1 Language</p>
6. Press +/- simultaneously to exit the "Service" function group.		
7. Press - until you get to the "Setup 1" function group. 8. Press E to be able to make your settings for "Setup 1".		 <p>SETUP HOLD A SETUP 1</p>
9. In A1, select the desired mode of operation, e.g. "mg/l" = oxygen concentration. Press E to confirm.	mg/l %SAT hPA	 <p>SETUP HOLD mg/l A1 Unit</p>
10. In A2, select display unit and press E to confirm.	mg/l ppm ppb	 <p>SETUP HOLD mg/l A2 Unit</p>
11. In A3, switch automatic pressure compensation on or off (version WX/WS/DS). Compensation takes account of both the altitude dependent and the weather dependent proportion of the air pressure. Press E to confirm.	off on	 <p>SETUP HOLD off A3 PressComp</p>
12. In A4, enter altitude if automatic pressure compensation is not available (version DX) or switched off. Press E to confirm.	0 m 0 ... 4000 m	 <p>SETUP HOLD 0 m A4 Altitude</p>

User input	Setting range (Factory settings, bold)	Display
13. In A5, enter measured value damping. Measured value damping causes averaging over the specified number of individual measured values. This is used for example, to stabilise the display if the measurement is unstable. Enter "1" if no damping is required. Press E to confirm.	1 1 ... 60	<p>SETUP HOLD 1 A5 Damping</p>
14. In A6, enter oxygen measuring range: OOS41, OOS61 or OOS71: select "20 mg/l" / "200 %SAT" / "400 hPa" OOS31: All measuring ranges possible Press E to confirm. Display returns to "Setup 1".	20 mg/l 60 mg/l 200 %SAT 600 %SAT 400 hPa 1200 hPa	<p>SETUP HOLD 20 mg/l A6 Range</p>
15. Press - to go to the "Setup 2" function group. 16. Press E to edit "Setup 2".		<p>SETUP HOLD B SETUP 2</p>
17. In B1, select salinity of the medium. Press E to confirm.	0.0 % 0.0 ... 4.0 %	<p>SETUP HOLD 0.0% B1 Salinity</p>
18. In B2, enter correct process temperature. Press E to confirm.	current meas. value -10 ... 60 °C	<p>SETUP HOLD 0.0 °C B2 RealTemp</p>
19. The difference between measured and entered temperature will be displayed. Press E . The display returns to "Setup 2".	current meas. value -5.0 ... 5.0 °C	<p>SETUP HOLD 0.0 °C B3 Temp. Offs</p>
20. Press +/- simultaneously to switch to the measuring mode.		

6.4 System configuration

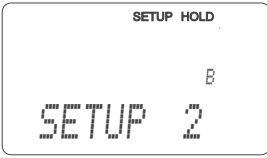
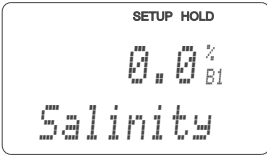
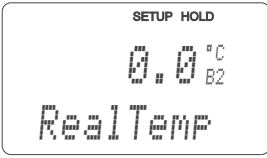
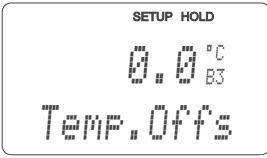
6.4.1 Setup 1 (Oxygen)

In the SETUP 1 function group, you can change the operating mode and the sensor settings.

Coding	Field	Selection or range (factory settings bold)	Display	Info
A	Function group SETUP 1			Basic settings.
A1	Select operating mode	mg/l %SAT hPa		mg/l = oxygen concentration %SAT = oxygen saturation index hPa = oxygen partial pressure  Caution! Any change in operating mode causes an automatic reset of user settings. If the oxygen value only needs to be read switch display using the PLUS key.
A2	Select display unit	mg/l ppm ppb		
A3	Switch automatic pressure compensation on or off	off on		Field only available with WX/WS or DS versions. The absolute air pressure is measured. Compensation takes account of both the altitude dependent and the weather dependent proportion of the air pressure.
A4	Enter altitude	0 m 0 ... 4000m		Only available if the pressure compensation in A2 is switched off or not available.
A5	Enter measured value damping	1 1 ... 60		Measured value damping causes averaging over the specified number of individual measured values. It is used, for example, to stabilise the display with applications that fluctuate a great deal. There is no damping if "1" is entered.
A6	Enter oxygen measuring range	20 mg/l, 20 ppm, 20000 ppb 60 mg/l, 60 ppm, 60000 ppb (depends on selected display unit) 200 % SAT 600 %SAT 400 hPa 1200 hPa		Sensor OOS41/61/71: Measuring must be 0 ... 20 mg/l (0 ... 200 %SAT, 0 ... 400 hPa) Sensor OOS31: Both measuring ranges possible.

6.4.2 Setup 2 (Salinity and temperature)

In the SETUP 2 function group, you can change the salinity and the temperature settings.

Coding	Field	Selection of range (factory settings bold)	Display	Info
B	Function group SETUP 2			Setups for salinity and temperature.
B1	Enter salinity	0,0 % 0,0 ... 4,0 %		Input of salinity.
B2	Enter correct process temperature	current meas. value -10,0 ... 60,0 °C		The display value can be edited. You can make an adjustment of max. ±5 °C. Due to the high accuracy, adjustment is not usually necessary.
B3	Displays temperature difference (offset)	Current offset -5,0 ... 5,0 °C		The offset is the difference between measured and entered temperature.

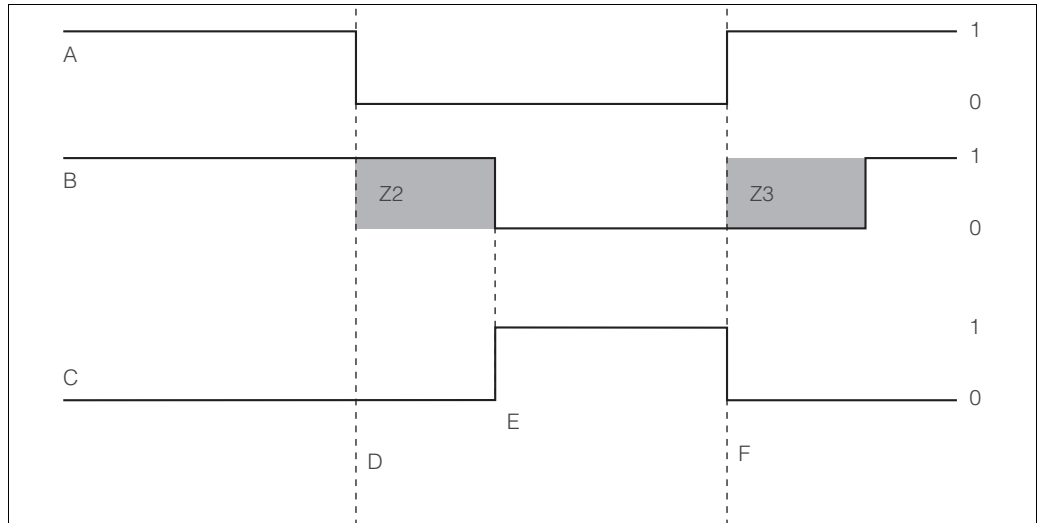
6.4.3 Current input

To use the "Current input" function group, you need a relay board with current input which is not part of the basic version. With this function group you can monitor process parameters and use these for feedforward control. For this purpose, you must connect the current output of an external measured variable (e.g. flowmeter) to the 4 ... 20 mA input of the transmitter. The following assignment applies:

	Flow in main stream	Current signal in mA	Current input signal in %
Current input lower range limit	Flowmeter lower setting value	4	0
Current input upper range limit	Flowmeter upper setting value	20	100

Monitoring of flow in main stream

This arrangement is particularly practical if the sample flow through a flow assembly in an open outlet is completely independent of the flow in the main stream. This permits signalling of an alarm condition in the main stream (flow too low or has completely stopped) and triggers dosing switch-off even if the medium flow is retained due to the method of installation.



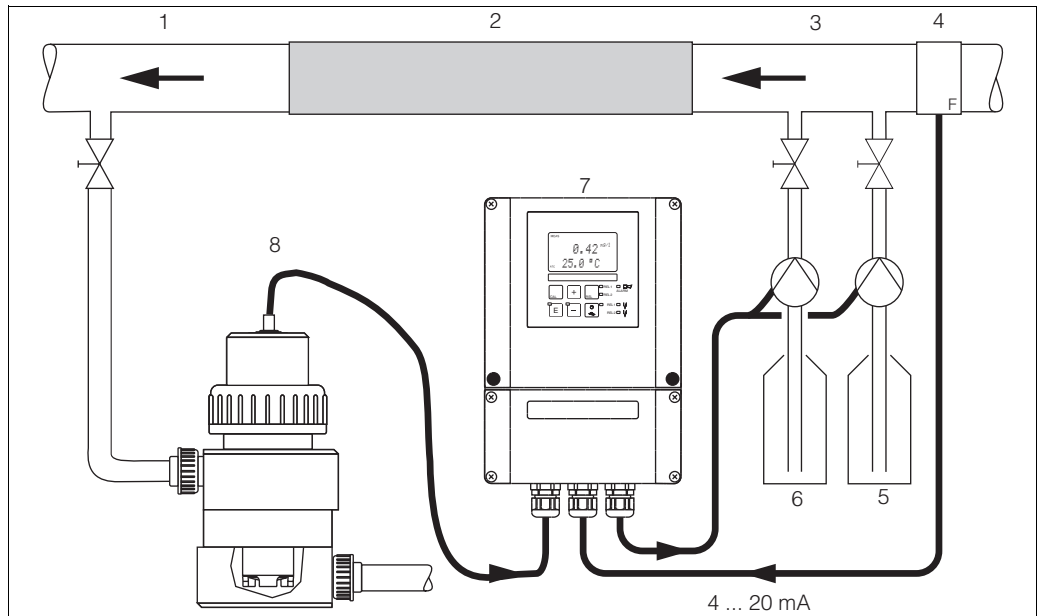
C07-OPM2x3xx-05-06-00-xx-001.eps

Fig. 30: Alarm signalling and dosing switch-off by the main stream

- | | | | |
|---|---|----|---|
| A | Flow in main stream | F | Flow restoration |
| B | Relay contacts of PID controller | Z2 | Delay for controller switch-off, see field Z2 |
| C | Alarm relay | Z3 | Delay for controller switch-on, see field Z3 |
| D | Flow below switch-off limit Z 4 or flow failure | 0 | Off |
| E | Flow alarm | 1 | On |

Feedforward control to PID controller

For control systems with very short reaction times, you can optimise the control. Additionally you measure the flow rate of the medium. This flow rate value (0/4 ... 20 mA) you apply as feedforward control to the PID controller.



C07-OPM2x3xx-05-06-00-xx-001.eps

- | | | | |
|---|----------------------------------|---|--------------------|
| 1 | Measuring water extraction point | 5 | Reducing agent |
| 2 | Static mixer | 6 | Oxidising agent |
| 3 | Injection points | 7 | Transmitter OOM253 |
| 4 | Flowmeter | 8 | OOA250 with OOS31 |

Feedforward control is a multiplying function as illustrated in the figure below (example with factory setting):

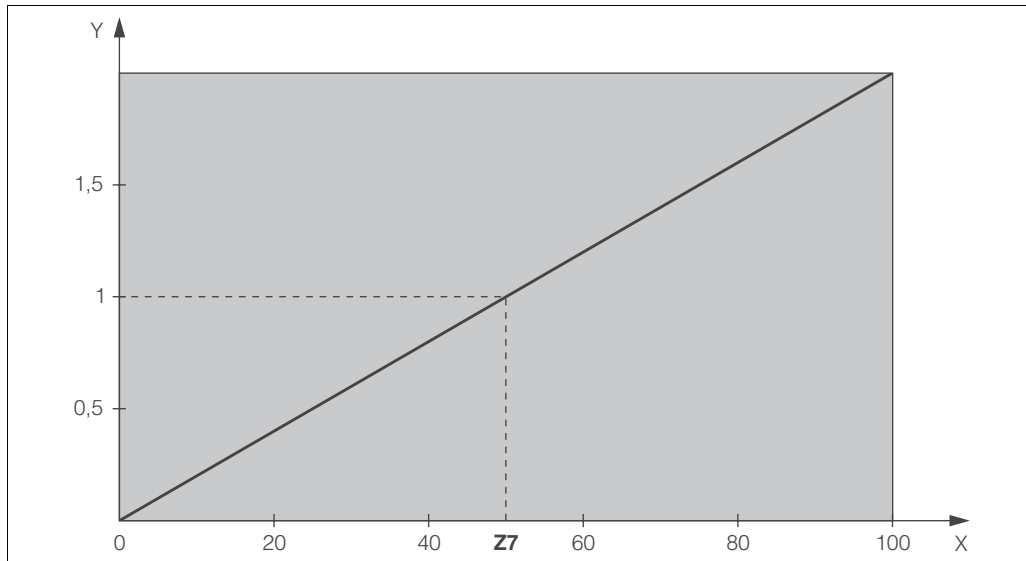


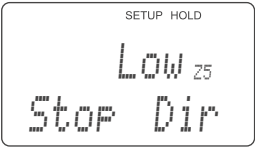
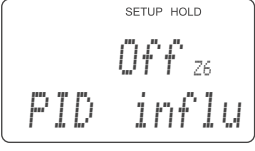
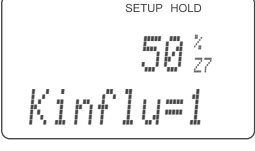
Fig. 32: Multiplying feedforward control

C07-OPM2x3xx-05-06-00-de-003.eps

- Y Gain K_{inff}
- X Current input signal [%]
- Z7 Input value, when gain $K_{inff} = 1$

Basic version does not include functions in *italic*.

Coding	Field	Setting range (Factory settings, bold)	Display	Info
Z	CURRENT INPUT function group			Current input settings.
Z1	Select flow monitoring of main stream (with controller switch-off)	Off On		Flow monitoring may only be switched on if the flowmeter is connected in the main stream. If Z1 = off, fields Z2 to Z5 are not available.
Z2	Enter the delay for controller switch-off through current input	0 s 0 ... 2000 s		Brief flow shortfalls can be suppressed by a delay and do not result in controller switch-off.
Z3	Enter the delay for controller switch-on through current input	0 s 0 ... 2000 s		In the case of a controller, a delay until a representative measured value is received is useful if the flow fails for an extended period.
Z4	Enter the switch-off limit value for the current input	50% 0 ... 100%		0 ... 100% corresponds to 4 ... 20 mA at the current input. Observe measured value assignment to the current output of the flowmeter.

Coding	Field	Setting range (Factory settings, bold)	Display	Info
Z5	Enter the switch-off direction for the current input	Low High		The controller is switched off if the value entered in Z4 is undershot or overshot.
Z6	Select feedforward control to PID controller	Off <i>Lin = linear</i> <i>Basic</i>		If Z6 = off, the field Z7 is not available. Z6 = basic: disturbance variable only affects the basic load (alternatively dosing in proportion to quantity if usual PID controller not possible, e.g. defective sensor).
Z7	Enter value for feedforward control at which gain = 1 applies	50% <i>0 ... 100%</i>		When the value is set, the controller actuating variable is the same size when feedforward control is switched on as when feedforward control is switched off.

6.4.4 Current outputs

Use the "Current output" function group to configure the individual outputs. You can enter either a linear characteristic (O3 (1)) or a user-defined current output characteristic in conjunction with the Plus Package (O3 (3)). Exception: if you have chosen a "continuous controller" for current output 2, you cannot enter a user-defined current output characteristic for this current output.

In addition, you can also simulate a current output value (O3 (2)) to check the current outputs. If a second current output is present, you can output the controller actuating variable in accordance with field R 237 via the current output.

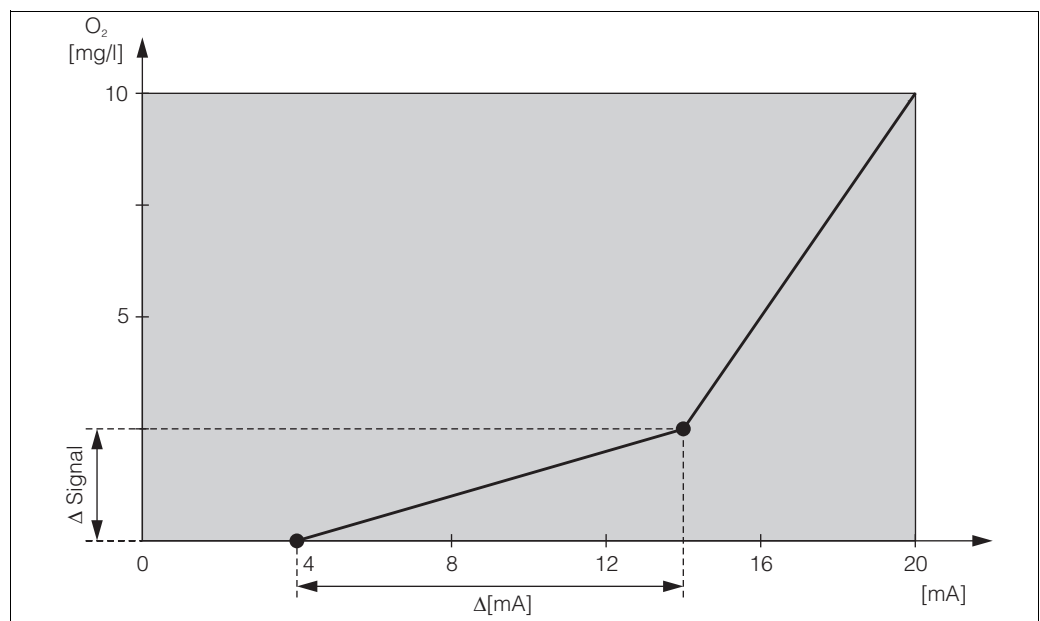


Fig. 33: User-defined current output characteristic (example)

The current output characteristic must be strictly monotonously increasing or strictly monotonously decreasing.

The distance per mA between two table value pairs must be greater than:

	Measuring range	Minimum distance per mA
Oxygen	0 ... 20 mg/l	0.13 mg/l
	0 ... 60 mg/l	0.38 mg/l
	0 ... 200 % SAT	1.30 % SAT
	0 ... 600 % SAT	3.80 % SAT
	0 ... 400 hPa	2.50 hPa
	0 ... 1200 hPa	7.50 hPa
Temperature	-10 ... 60 °C (14 ... 140 °F)	0.45 °C (0.81 °F)

The values for the sample characteristic (Fig. 33) are entered in the following table. The distance per mA can be calculated from $\Delta \text{signal} / \Delta \text{mA}$.

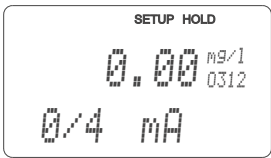
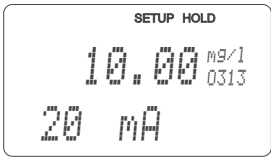
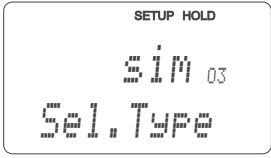
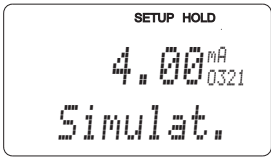
Value pair	Current output 1			Current output 2		
	[mg/l; %SAT; hPa]	Current [mA]	Distance per mA	[mg/l; %SAT; hPa]	Current [mA]	Distance per mA
1	0	4				
2	2.5	14	0.25			
3	10	20	1.25			

First enter the desired current output configuration into the following blank table with a pencil. Calculate the resulting signal distance per mA to observe the necessary minimum slope. Then enter the values in the device.

Value pair	Current output 1			Current output 2		
	[mg/l; %SAT; hPa]	Current [mA]	Distance per mA	[mg/l; %SAT; hPa]	Current [mA]	Distance per mA
1						
2						
3						
4						
5						
6						
7						
8						
9						

Basic version does not include functions in *italic*.

Coding	Field	Setting range (Factory settings, bold)	Display	Info
O	CURRENT OUTPUT function group			Configuration of the current output (does not apply for PROFIBUS).
	O1	Select current output Out1 <i>Out 2</i>		A characteristic can be selected for every output.
	O2	Select measured variable for 2nd current output °C <i>mg/l</i> <i>ppm</i> <i>Contr</i>		R237 = curr (current output 2) can only be selected if O2 = Contr is selected (relay board required).
	O3 (1)	Enter or output linear characteristic Lin = linear (1) <i>Sim = simulation (2)</i> <i>Tab = table (3)</i>		The characteristic can have a positive or negative slope for the measured value output. In the case of actuating variable output (O2 = Contr), an increasing current corresponds to an increasing actuating variable.
	O311	Select current range 4 ... 20 mA <i>0 ... 20 mA</i>		

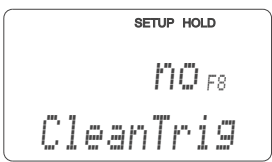
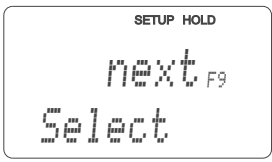
Coding		Field	Setting range (Factory settings, bold)	Display	Info
	O312	0/4 mA value: Enter corresponding O ₂ or temperature value	– Version DX/DS or WX/WS with OOS61: 0.00 mg/l* 0.00 ... 20.00 mg/l 0.0 %SAT 0.0 ...200.0 %SAT 0 hPa 0 ... 400 hPa – WX/WS with OOS31: 0.00 mg/l* 0.00 ... 60.00 mg/l 0.0 %SAT 0.0 ... 600.0 %SAT 0 hPa 0 ... 1200 hPa – WX/WS with OOS71: 0.000 mg/l* 0.000 ... 20.000 mg/l 0.0 %SAT 0.0 ... 200.0 %SAT 0 hPa 0 ... 400 hPa 0.0 °C -10.0 ... 60.0 °C		Here you can enter the O ₂ or temperature value at which the min. current value (0/4 mA) is applied at the transmitter output. Minimum distance between 0/4 mA and 20 mA value: see field O313 * Display depends on setting in A2
	O313	20 mA value: Enter corresponding O ₂ or temperature value	– Version DX/DS or WX/WS with OOS61: 10.00 mg/l* 0.00 ... 20.00 mg/l 100.0 %SAT 0.0 ...200.0 %SAT 200 hPa 0 ... 400 hPa – WX/WS with OOS31: 10.00 mg/l* 0.00 ... 60.00 mg/l 100.0 %SAT 0.0 ... 600.0 %SAT 200 hPa 0 ... 1200 hPa – WX/WS with OOS71: 10.000 mg/l* 0.000 ... 20.000 mg/l 100.0 %SAT 0.0 ... 200.0 %SAT 200 hPa 0 ... 400 hPa 40.0 °C -10.0 ... 60.0 °C		Here you can enter the O ₂ or temperature value at which the max. current value (20 mA) is applied at the transmitter output. Minimum distance between 0/4 mA and 20 mA value must be: Oxygen: – DX/DS or WX/WS with OOS61: 0.2 mg/l / 2 %SAT / 4 hPa – WX/WS with OOS31: 0.6 mg/l / 6 %SAT / 12 hPa – WX/WS with OOS71: 0.02 mg/l / 0.2 %SAT / 0.4 hPa Temperature: All versions: 7 °C * Display depends on setting in A2
O3 (2)		Simulate current output	Lin = linear (1) Sim = simulation (2) Tab = table (3)		Simulation is not ended until (1) or (3) is selected. For further characteristics, see O3 (1), O3(3).
	O321	Enter simulation value	Current value 0.00 ... 22.00 mA		Entering a current value results in this value being directly output at the current output.

Coding		Field	Setting range (Factory settings, bold)	Display	Info
	O3 (3)	Enter current output table (only for Plus Package)	Lin = linear (1) Sim = simulation (2) Tab = table (3)		Values can also be added or altered at a later stage. The values entered are automatically sorted by increasing current value. For further characteristics, see O3 (1), O3 (2).
	O331	Select table options	Read Edit		
	O332	Enter number of table value pairs	1 1 ... 10		Enter the number of pairs from the x and y value (measured value and current value) here.
	O333	Select table value pair	1 1 ... No. elem. Assign		The function chain O333 ... O335 will run through as many times as correspond to the value in O332. "Assign" appears as the last step. After confirmation the system jumps to O336.
	O334	Enter x value	– Version DX/DS or WX/WS with OOS61: 0.00 mg/l* 0.00 ... 20.00 mg/l 0.0 %SAT 0.0 ... 200.0 %SAT 0 hPa 0 ... 400 hPa – WX/WS with OOS31: 0.00 mg/l* 0.00 ... 60.00 mg/l 00.0 %SAT 0.0 ... 600.0 %SAT 0 hPa 0 ... 1200 hPa – WX/WS with OOS71: 0.000 mg/l* 0.000 ... 20.000 mg/l 0.0 %SAT 0.0 ... 200.0 %SAT 0 hPa 0 ... 400 hPa 0.0 °C -10.0 ... 60.0 °C		x value = measured value specified by user. * Display depends on setting in A2
	O335	Enter y value	4.00 mA 0.00 ... 20.00 mA		y value = current value belonging to O334 specified by user. Return to O333 until all values are entered.
	O336	Message as to whether table status is OK	yes no		Back to O3. If status = no, correct table (all settings made up until now are retained) or back to measuring mode (table is deleted).

6.4.5 Monitoring functions

The monitoring functions are used to define various alarms and configure output contacts. Each individual error can be defined to be effective or not (at the contact or as an error current). An alarm condition can be defined to activate a cleaning function (F8)

Coding	Field	Setting range (Factory settings, bold)	Display	Info
F	ALARM function group			Alarm function settings.
F1	Select contact type	Latch = latching contact Momen = momentary contact		The contact type selected only applies to the alarm contact.
F2	Select time unit	s min		
F3	Enter alarm delay	0 s (min) 0 ... 2000 s (min)		Depending on the option selected in F2, the alarm delay is entered in s or min.
F4	Select error current	22 mA 2.4 mA		This selection must be made even if all error reporting is switched off in F5. Caution! If "0-20 mA" was selected in O311, "2.4 mA" may not be used.
F5	Select error	1 1 ... 255		Here you can select all the errors which should trigger an alarm. The errors are selected via the error numbers. Please refer to the table in section 9.2 "System error messages" for the meaning of the individual error numbers. The factory settings remain in effect for all errors not edited.
F6	Set alarm contact to be effective for the selected error	yes no		If "no" is selected, all the other alarm settings are deactivated (e.g. alarm delay). The settings themselves are retained. This setting only applies to the error selected in F5.
F7	Set error current to be effective for the selected error	no yes		The option selected in F4 is effective or ineffective in the event of an error. This setting only applies to the error selected in F5.

Coding		Field	Setting range (Factory settings, bold)	Display	Info
	F8	Automatic cleaning function start	no yes		This field is not available for certain errors, see "Trouble-shooting and fault elimination" section.
	F9	Select return to menu or next error	next = next error ←R		If ←R is selected, you return to F, if next is selected, you go to F5.

Check

The CHECK function group is only available for devices with a Plus Package. In the CHECK function group, you can select different monitoring functions for the measurement.

All the monitoring functions are off in the factory setting. The Sensor Check System adapts to the current application conditions by adding and setting suitable functions.

Alarm threshold monitoring

For oxygen measurement without entry control (ventilation) sensor errors lead to a measured value error, but have no impact on the process medium (examples: monitoring measurement in surface waters or in water-works). Sensor errors normally cause high or low readings that are implausible. This is detected and signalled by user-definable alarm thresholds.

Controller monitoring

For oxygen measurement with simultaneous entry control, sensor errors not only lead to incorrect measured values but also have a direct impact on the state of the process medium. Particularly in the case of oxygenation control in sewage treatment works, the risk exists due to the control loop that the ventilation does not switch on if the measured value is constantly too high. A too low oxygen supply creates a considerable risk for the microbes and their cleaning performance. On the other hand, a measured value which is permanently too low due to the uninterrupted operation of the ventilation units leads to increased operating costs. Such cases are recognised and signalled using freely settable monitoring times for the maximum permitted controller switch-on and switch-off periods.

Sensor activity monitoring

The process medium can also have an effect on the sensor leading to incorrect measured values. The collection of solid matter at the sensor or a strong coating on the sensor membrane can lead to a strongly-delayed or completely passive measuring signal. Constant monitoring of the signal activity recognises and signals such passivity.

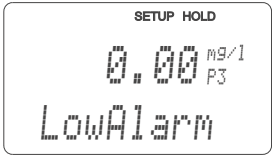
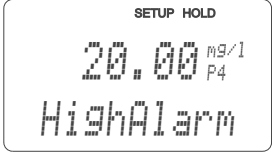
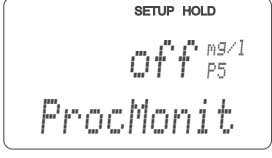
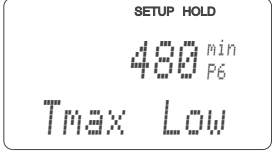
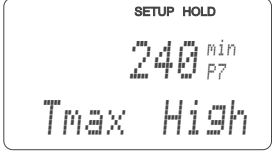
SCS monitoring functions at a glance

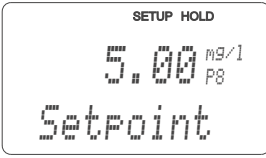
	Functional description	Setting possibility	Alarm event	Application
Alarm threshold monitoring (P1 ... P4)	<ul style="list-style-type: none"> – freely adjustable lower alarm threshold (AT) – freely adjustable upper alarm threshold (AT) 	off	—	Applications with or without oxygenation control
		only lower AT	lower AT reached or dropped below	
		only upper AT	upper AT reached or exceeded	
		lower and upper AT	lower AT reached or dropped below or upper AT reached or exceeded	
Controller monitoring (CC: Controller Check, P5 ... P8)	<ul style="list-style-type: none"> – Switch-on period monitoring – Switch-off period monitoring 	off	—	Applications with oxygenation control
		on	Set maximum period for permanent switch-on or switch-off exceeded	
Sensor activity monitoring (AC: Alternation Check, P5 ... P8)	Monitoring for signal change	off	—	Applications with or without oxygenation control
		on	Change within 1 hour < ±0.1 mg/l or ±1 %SAT or ±2 hPa	

The function group "Check" is used to monitor the lower and upper limits of the measured value and to initiate alarms.

Basic version does not include functions in *italic*.

Coding	Field	Setting range (Factory settings, bold)	Display	Info
P	CHECK function group			Settings for sensor and process monitoring
P1	<i>Select alarm threshold monitoring</i>	Off <i>Low</i> <i>High</i> <i>Lo+Hi</i> <i>Low!</i> <i>High!</i> <i>Lo+Hi!</i>		Alarm signalling optionally with or without simultaneous controller switch-off. XXXX = without controller switch-off XXXX! = with controller switch-off
P2	<i>Enter alarm delay</i>	0 s (min) <i>0 ... 2000 s (min)</i>		Depending on your selection in F2, you can enter the error delay in min or s. Only after this delay does a high or low limit violation cause an alarm as per field P3/ P4.

Coding	Field	Setting range (Factory settings, bold)	Display	Info
P3	Enter lower alarm threshold	– Version DX/DS or WX/WS with OOS61: 0.00 mg/l* 0.00 ... 19.00 mg/l 0.0 %SAT 0.0 ... 190.0 %SAT 0 hPa 0 ... 380 hPa – WX/WS with OOS31: 0.00 mg/l* 0.00 ... 59.00 mg/l 0.0 %SAT 0.0 ... 590.0 %SAT 0 hPa 0 ... 1180 hPa – WX/WS with OOS71: 0.000 mg/l* 0.000 ... 19.000 mg/l 0.0 %SAT 0.0 ... 190.0 %SAT 0 hPa 0 ... 380 hPa		* Display depends on setting in A2
P4	Enter upper alarm threshold	– Version DX/DS or WX/WS with OOS61: 20.00 mg/l* 1.00 ... 20.00 mg/l 200.0 %SAT 0.0 ... 200.0 %SAT 400 hPa 20 ... 400 hPa – WX/WS with OOS31: 20.00 mg/l* 1.00 ... 60.00 mg/l 200.0 %SAT 10.0 ... 600.0 %SAT 400 hPa 20 ... 1200 hPa – WX/WS with OOS71: 20.000 mg/l* 0.010 ... 20.000 mg/l 200.0 %SAT 0.5 ... 200.0 %SAT 400 hPa 20 ... 400 hPa		* Display depends on setting in A2
P5	Select process monitoring (PCS alarm)	Off AC CC AC+CC AC! CC! AC+CC!		AC = sensor activity check CC = controller check AC checking limits: ±0.1 mg/l or ±1 %SAT or ±2 hPa in 1 h XXXX = without controller switch-off XXXX! = with controller switch-off
P6	Enter maximum permissible duration for lower CC setpoint limit violation (field P8)	480 min 0 ... 2000 min		Only when P6 = CC or AC+CC
P7	Enter maximum permissible duration for upper CC setpoint limit violation (field P8)	240 min 0 ... 2000 min		Only when P6 = CC or AC+CC

Coding	Field	Setting range (Factory settings, bold)	Display	Info
P8	Enter CC setpoint (for P6/P7)	– Version DX/DS or WX/WS with OOS61: 5.00 mg/l* 0.00 ... 20.00 mg/l 50.0 %SAT 0.0 ... 200.0 %SAT 200 hPa 0 ... 400 hPa – WX/WS with OOS31: 5.00 mg/l* 0.00 ... 60.00 mg/l 50.0 %SAT 0.0 ... 600.0 %SAT 200 hPa 0 ... 1200 hPa – WX/WS with OOS71: 1.000 mg/l* 0.000 ... 20.000 mg/l 10.0 %SAT 0.0 ... 200.0 %SAT 20 hPa 0 ... 400 hPa		Setpoint for external controller (process control system) must match with setpoint in P8. * Display depends on setting in A2

6.4.6 Relay contact configuration

To use the RELAY function group, you need a relay board which is not part of the basic version.

The following relay contacts can be selected and configured as desired (max. four contacts, depending on options installed):

- Limit contactor for measured oxygen value: R2 (1)
- Limit contactor for temperature: R2 (2)
- PID controller: R2 (3)
- Timer for cleaning function: R2 (4)
- Chemoclean function: R2 (5)

Limit contactor for measured oxygen value and temperature

The transmitter has different ways of assigning a relay contact.

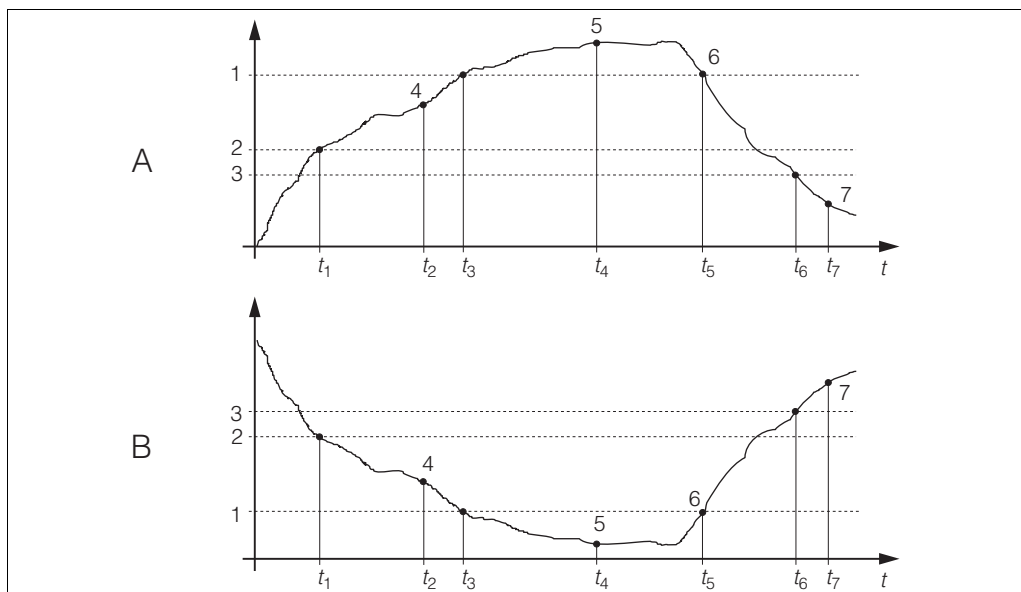
Switch-on and switch-off points and pick-up and drop-out delays can be assigned to the limit contactor. In addition, you can configure an alarm threshold to output an error message and to start a cleaning function in conjunction with this.

These functions can be used both for oxygen measurement and for temperature measurement.

Please refer to Fig. 34 for a clear illustration of the relay contact states.

- When the measured values increase (maximum function), the relay contact is closed as of t_2 after the switch-on point (t_1) has been overshoot and the pick-up delay has elapsed ($t_2 - t_1$). The alarm contact switches if the alarm threshold (t_3) is reached and the alarm delay ($t_4 - t_3$) has also elapsed.
- When the measured values decrease, the alarm contact is reset when the alarm threshold (t_5) is undershot as is the relay contact (t_7) after the drop-out delay ($t_7 - t_6$).
- If the pick-up and drop-out delays are set to 0 s, the switch-on and switch-off points are also switch points of the contacts.

Settings can also be made for a minimum function in the same way as for a maximum function.



C07-OxM2x3xx-05-06-00-xx-003.eps

Fig. 34: Illustration of the alarm and limit value functions

A	Switch-on point > switch-off point: Max. function	1	Alarm threshold	5	Alarm ON
B	Switch-on point < switch-off point: Min. function	2	Switch-on point	6	Alarm OFF
		3	Switch-off point	7	Contact OFF
		4	Contact ON		

P(ID) controller

You can define various controller functions for the transmitter. On the basis of the PID controller, P, PI, PD and PID controllers can be implemented. For an optimum control system, use the controller that best suits your application. Depending on the option selected in the R 237 / R 266 field, the actuating signal can be output via relays or via current output 2 (if available).

- **P controller**
Used for simple linear control purposes with small system deviations. Where major changes are to be controlled, overshooting may occur. In addition, a lasting control deviation is to be expected.
- **PI controller**
Is used for control systems where overshooting is to be avoided and no lasting control deviation should occur.
- **PD controller**
Is used for processes that require quick changes and where peaks are to be corrected.
- **PID controller**
Is used for processes where a P, PI or PD controller does not control sufficiently.

Configuration options of the PID controller

The following configuration options are available for a PID controller:

- Change control gain K_p (P influence)
- Set integral action time T_n (I influence)
- Set derivative action time T_v (D influence)

Basic load dosing (Basic)

The basic load dosing (field R231) is used to set a constant dosage (field R2311)

PID controlling plus basic load dosing

If you select this function (PID + Basic) in field R231 the PID controlled dosage will not be lower than the basic load value entered in field R2311.

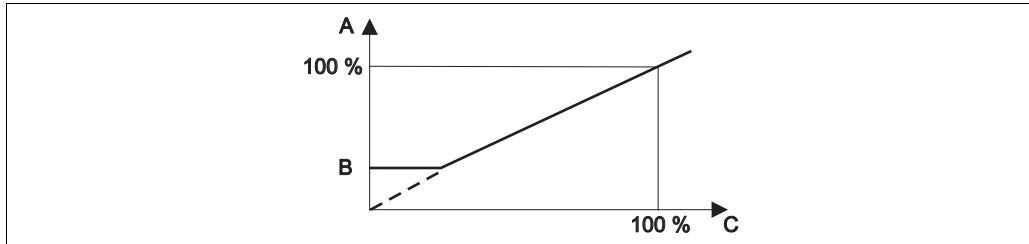


Fig. 35: Control characteristic PID controller with basic load dosing

C07-OxM2x3xx-05-06-00-xx-010.eps

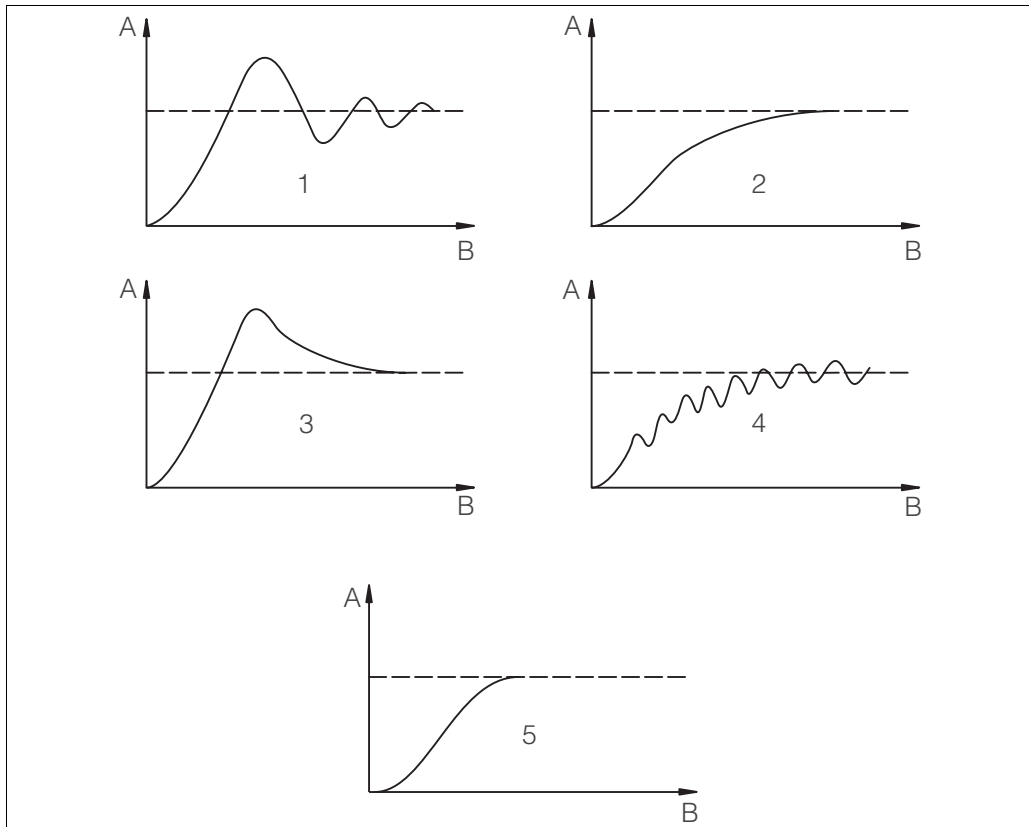
- A PID with basic load
- B Basic load
- C PID

Commissioning

If you do not yet have any experience for setting the control parameters, set the values that yield the greatest possible stability in the control circuit. Proceed as follows to optimise the control circuit further:

- Increase the control gain K_p until the controlled variable just starts to overshoot.
- Reduce K_p slightly and then reduce the integral action time T_n so that the shortest possible correction time without overshooting is achieved.
- To reduce the response time of the controller, also set the derivative action time T_v .

Control and fine optimisation of the set parameters with a recorder



C07-OxM2x3xx-05-06-00-xx-004.eps

Fig. 36: Optimisation of settings T_n and K_p

- | | | | | | |
|---|--------------|---|-----------------|---|-----------------|
| A | Actual value | 1 | T_n too small | 4 | K_p too small |
| B | Time | 2 | T_n too large | 5 | Optimum setting |
| | | 3 | K_p too large | | |

Actuating signal outputs (R237 ... R2310)

Each control contact outputs a cyclical signal whose intensity corresponds to the controller's manipulated variable. A distinction is made according to the type of signal cycle:

- Pulse length modulation
The bigger the calculated manipulated variable is, the longer the contact affected remains picked up. The period T can be adjusted between 0.5 and 99 s (field R238). Outputs with pulse length modulation are used to activate solenoid valves.
- Pulse frequency modulation
The bigger the calculated manipulated variable is, the higher the switching frequency of the contact affected. The maximum switching frequency $1/T$ can be set between 60 and 180 min^{-1} . The on-time t_{ON} is constant. It depends on the set maximum frequency and is approx. 0.5 s for 60 min^{-1} and approx. 170 ms for 180 min^{-1} . Outputs with pulse frequency modulation are used to activate directly controlled solenoid dosing pumps.

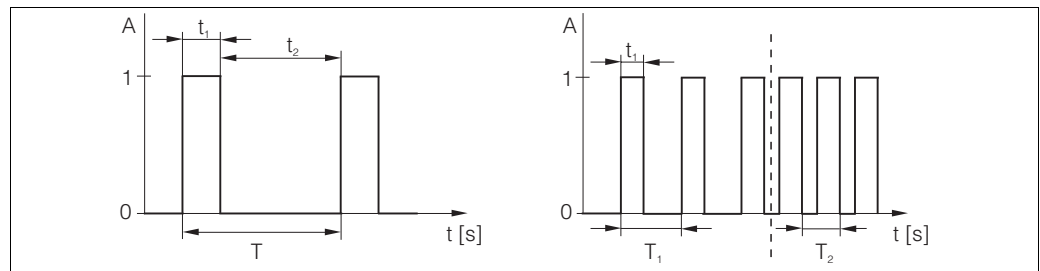


Fig. 37: Signal of a pulse-length modulated controller contact (left) and of a pulse-frequency modulated controller contact (right)

- A Contact 1 = on, 0 = off
- B Time [s] $t_1 = t_{\text{on}}$ $t_2 = t_{\text{off}}$
- T Period length
- $T_1 T_2$ Impulse period length (impulse freq. $1/T_1$ and $1/T_2$)

Constant controller

Via the current output 2, the minimum actuating variable (0 %) of the controller is output with 0/4 mA and the maximum actuating variable (100%) of the controller is output with 20 mA.

Control characteristic for direct and inverse control action

You can choose between two control characteristics in the R236 field:

- Direct control action = maximum function
- Inverse control action = minimum function

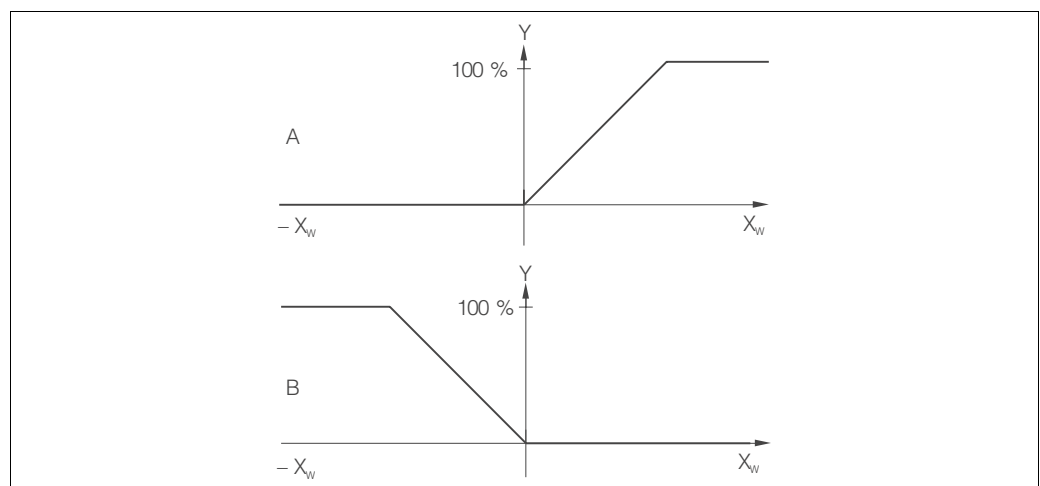


Fig. 38: Control characteristic of a proportional controller with direct and inverse control action

- A Direct = max. function
- B Inverse = min. function

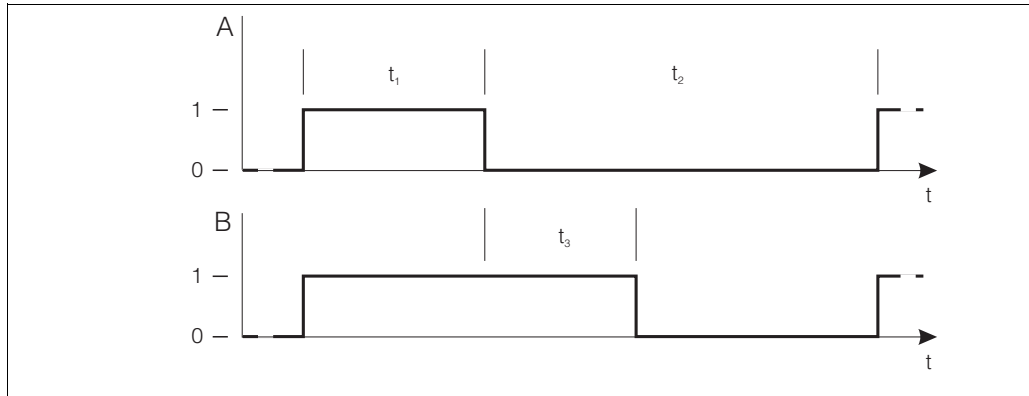
Timer for cleaning function

This function includes a simple cleaning option. You can set the time interval after which cleaning should start. So you can only select a constant interval sequence. Other cleaning functions are available for selection in conjunction with the Chemoclean function (version with four contacts, see "Chemoclean function" section).



Note!

Timer and Chemoclean do not work independently of one another. While one of the two functions is active, the other cannot be started.



C07-OLM2x3xx-05-06-xx-007.eps

Abb. 39: Connection between cleaning time, pause time and Hold dwell period

A	Wiper and/or spray cleaning system	t_1	Cleaning time (0 ... 999 s)
B	Hold function	t_2	Pause time between two cleaning intervals (1 ... 7200 min)
0	Inactive	t_3	Clean Hold dwell period (0 ... 999 s)
1	Active		

Chemoclean function

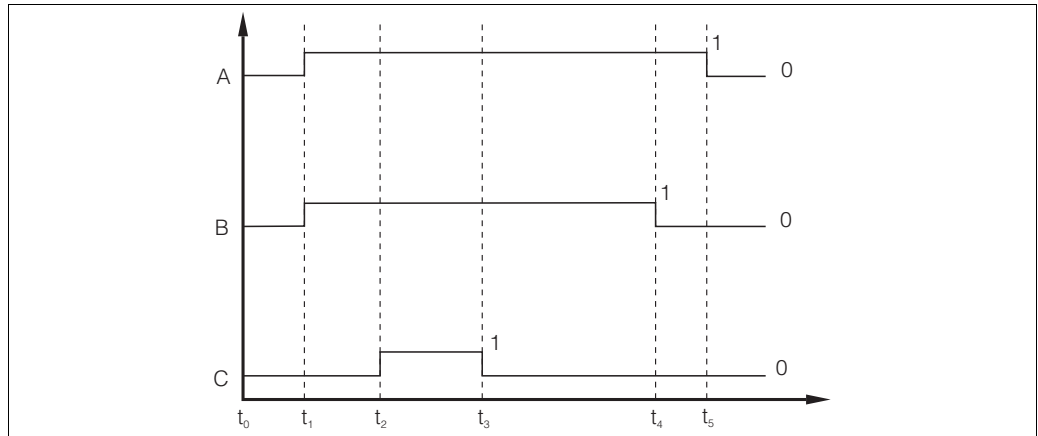
Just like the timer function, Chemoclean can also be used to start a cleaning cycle. However, Chemoclean also gives you the added option of defining different cleaning and rinsing intervals.

As a result, it is possible to clean irregularly with different repeat cycles and to separately set the cleaning times with post rinse times.



Note!

- To use the Chemoclean function the transmitter has to be equipped with a designated relay board (see product structure or chapter "accessories").
- Timer and Chemoclean do not work independently of one another. While one of the two functions is active, the other cannot be started.
- For the Chemoclean function, the relays 3 (water) and 4 (cleaner) are used.
- If the cleaning is prematurely aborted, a post rinse time always follows.
- If the setting is "Economy", cleaning only takes place with water.



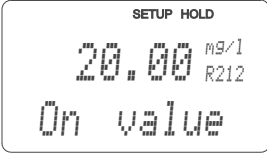

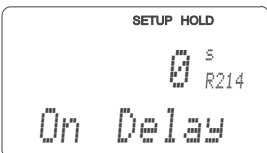
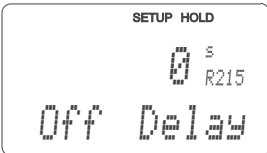
C07-OxM2x3xx-05-06-00-xx-008.eps

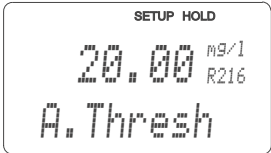

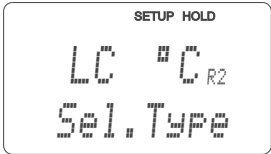
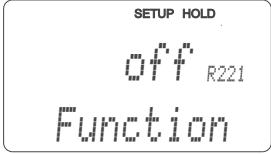
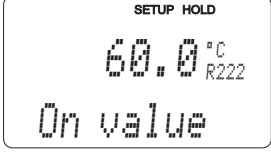
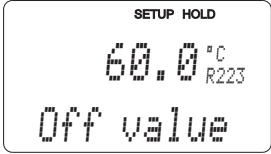
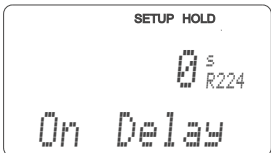
Fig. 40: Sequence of a cleaning cycle

- | | | | |
|---|---------|-------------|-------------------|
| A | Hold | t_1 | Cleaning start |
| B | Water | $t_2 - t_1$ | Pre-rinse time |
| C | Cleaner | $t_3 - t_2$ | Cleaning time |
| | | $t_4 - t_3$ | Post rinse time |
| | | $t_5 - t_4$ | Hold dwell period |

Basic version does not include functions in *italic*.

Coding	Field	Setting range (Factory settings, bold)	Display	Info
R	RELAY function group			Relay contact settings.
R1	Select contact to be configured	Rel1 <i>Rel2</i> <i>Rel3</i> <i>Rel4</i>		Rel3 (water) and Rel4 (cleaner) are only available with the relevant version of the transmitter. If Chemoclean is used as the cleaning method, Rel4 is not available.
R2 (1)	Configuration limit contactor for O ₂ measurement	LC PV = limit contactor O₂ (1) LC °C = limit contactor T (2) PID controller (3) Timer (4) <i>Clean = Chemoclean (5)</i>		PV = process value If Rel4 is selected in the R1 field, Clean = Chemoclean cannot be selected. By confirming with ENTER, another relay function already switched on is switched off and its settings are reset to the factory settings.
R211	Switch function of R2 (1) off or on	Off On		All the settings are retained.

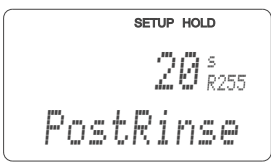
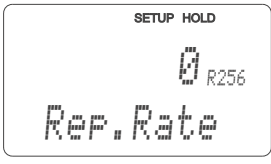
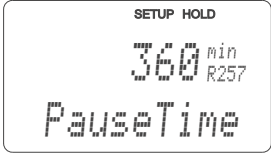
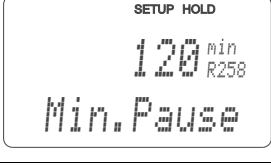
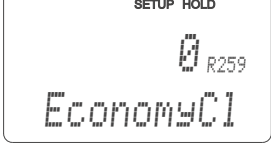
Coding		Field	Setting range (Factory settings, bold)	Display	Info
	R212	Enter the switch-on point of the contact	– Version DX/DS or WX/WS with OOS61: 20.00 mg/l* 0.00 ... 20.00 mg/l 200.0 %SAT 0.0 ...200.0 %SAT 400 hPa 0 ... 400 hPa – WX/WS with OOS31: 20.00 mg/l* 0.00 ... 60.00 mg/l 200.0 %SAT 0.0 ... 600.0 %SAT 400 hPa 0 ... 1200 hPa – WX/WS with OOS71: 20.000 mg/l* 0.000 ... 20.000 mg/l 200.0 %SAT 0.0 ... 200.0 %SAT 400 hPa 0 ... 400 hPa		Never set the switch-on point and the switch-off point to the same value! (Only the operating mode selected in A1 is displayed.) * Display depends on setting in A2
	R213	Enter the switch-off point of the contact	– Version DX/DS or WX/WS with OOS61: 20.00 mg/l* 0.00 ... 20.00 mg/l 200.0 %SAT 0.0 ...200.0 %SAT 400 hPa 0 ... 400 hPa – WX/WS with OOS31: 20.00 mg/l* 0.00 ... 60.00 mg/l 200.0 %SAT 0.0 ... 600.0 %SAT 400 hPa 0 ... 1200 hPa – WX/WS with OOS71: 20.000 mg/l* 0.000 ... 20.000 mg/l 200.0 %SAT 0.0 ... 200.0 %SAT 400 hPa 0 ... 400 hPa		Entering a switch-off point selects either a Max contact (switch-off point < switch-on point) or a Min contact (switch-off point > switch-on point), thereby implementing a hysteresis that is constantly required (see "Illustration of the alarm and limit functions" figure). (Only the operating mode selected in A1 is displayed.) * Display depends on setting in A2
	R214	Enter pick-up delay	0 s 0 ... 2000 s		
	R215	Enter drop-out delay	0 s 0 ... 2000 s		

Coding		Field	Setting range (Factory settings, bold)	Display	Info
	R216	Enter alarm threshold	– Version DX/DS or WX/WS with OOS61: 20.00 mg/l* 0.00 ... 20.00 mg/l 200.0 %SAT 0.0 ...200.0 %SAT 400 hPa 0 ... 400 hPa – WX/WS with OOS31: 20.00 mg/l* 0.00 ... 60.00 mg/l 200.0 %SAT 0.0 ... 600.0 %SAT 400 hPa 0 ... 1200 hPa – WX/WS with OOS71: 20.000 mg/l* 0.000 ... 20.000 mg/l 200.0 %SAT 0.0 ... 200.0 %SAT 400 hPa 0 ... 400 hPa		If the alarm threshold is undershot/overshot, this triggers an alarm with the error message and error current at the transmitter (note alarm delay in field F3). If defined as a Min contact, the alarm threshold must be < switch-off point. (Only the operating mode selected in A1 is displayed.) * Display depends on setting in A2
	R217	Display status for limit contactor	MAX MIN		Display only.
R2 (2)		Configure limit contactor for temperature measurement	LC PV = limit contactor O ₂ (1) LC °C = limit contactor T (2) PID controller (3) Timer (4) Clean = Chemoclean (5)		By confirming with ENTER, another relay function already switched on is switched off and its settings are reset to the factory settings.
	R221	Switch function of R2 (2) off or on	Off On		Settings made for the limit contactor are not deleted by switching the function off.
	R222	Enter switch-on temperature	60.0 C (140 °F) -10.0 ... 60.0 C (14 ... 140 °F)		Never set the switch-on point and the switch-off point to the same value!
	R223	Enter switch-off temperature	60.0 C (140 °F) -10.0 ... 60.0 C (14 ... 140 °F)		Entering a switch-off point selects either a Max contact (switch-off point < switch-on point) or a Min contact (switch-off point > switch-on point), thereby implementing a hysteresis that is constantly required (see "Illustration of the alarm and limit functions" figure).
	R224	Enter pick-up delay	0 s 0 ... 2000 s		

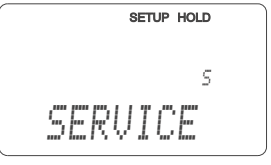
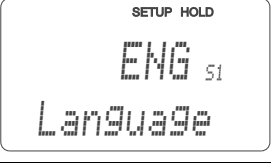
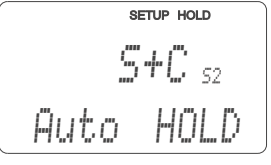
Coding		Field	Setting range (Factory settings, bold)	Display	Info
	R225	Enter drop-out delay	0 s 0 ... 2000 s		
	R226	Enter alarm threshold (as absolute value)	60.0 C (140 °F) -10.0 ... 60.0 C (14 ... 140 °F)		If the alarm threshold is undershot/overshot, this triggers an alarm with the error message and error current at the transmitter (note alarm delay in field F3). If defined as a Min contact, the alarm threshold must be < switch-off point.
	R227	Display status for limit contactor	MAX MIN		Display only.
R2 (3)		Configure P(ID) controller	LC PV = limit contactor O ₂ (1) LC °C = limit contactor T (2) PID controller (3) Timer (4) <i>Clean = Chemoclean (5)</i>		By confirming with ENTER, another relay function already switched on is switched off and its settings are reset to the factory settings.
	R231	Switch function of R2 (3) off or on	Off On Basic PID+B		On = PID controller Basic = basic load dosing PID+B = PID controller + basic load dosing
	R232	Enter set point	– Version DX/DS or WX/WS with OOS61: 5.00 mg/l* 0.00 ... 20.00 mg/l 50.0 %SAT 0.0 ... 200.0 %SAT 200 hPa 0 ... 400 hPa – WX/WS with OOS31: 5.00 mg/l* 0.00 ... 60.00 mg/l 50.0 %SAT 0.0 ... 600.0 %SAT 200 hPa 0 ... 1200 hPa – WX/WS with OOS71: 5.000 mg/l* 0.000 ... 20.000 mg/l 50.0 %SAT 0.0 ... 200.0 %SAT 200 hPa 0 ... 400 hPa		The set point is the value to be maintained by the control system. Using this control process, this value is restored upwards or downwards when a deviation occurs. (Only the operating mode selected in A1 is displayed.) * Display depends on setting in A2
	R233	Enter control gain K _p	1.00 0.01 ... 20.00		See "P(ID) controller" section.

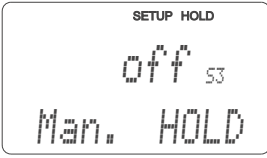
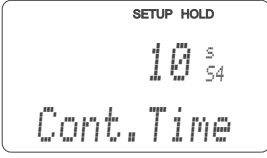
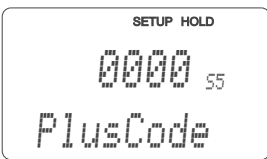
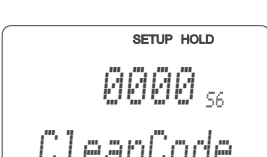
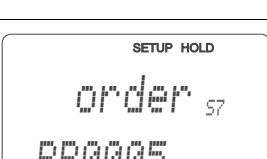
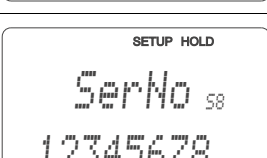

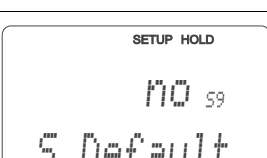
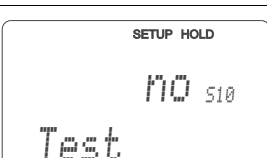
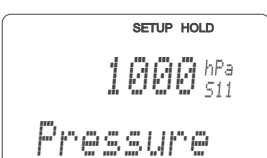
Coding		Field	Setting range (Factory settings, bold)	Display	Info
	R234	Enter integral action time T_n (0.0 = no I-component)	0.0 min 0.0 ... 999.9 min		See "P(ID) controller" section. With every Hold, the I-component is set to zero. Although Hold can be deactivated in field S2, this does not apply for Chemoclean and timer!
	R235	Enter derivative action time T_v (0.0 = no D-component)	0.0 min 0.0 ... 999.9 min		See "P(ID) controller" section.
	R236	Select controller characteristic	dir = direct inv = inverse		dir = Max. function inv = Min. function The setting is required depending on the control deviation (upward or downward deviation, see "P(ID) controller" section).
	R237	Select pulse length or pulse frequency	len = pulse length freq = pulse frequency curr = current output 2		Pulse length e.g. for solenoid valve, pulse frequency e.g. for solenoid dosing pump, see "Actuating signal outputs" section. Curr = current output 2 can only be selected if O2 = Contr.
	R238	Enter pulse interval	10.0 s 0.5 ... 999.9 s		This field only appears if pulse length is selected in R237. If pulse frequency is selected, R238 is skipped and entries continue with R239.
	R239	Enter maximum pulse frequency of the adjuster	120 min⁻¹ 60 ... 180 min ⁻¹		This field only appears if pulse frequency is selected in R237. If pulse length is selected, R239 is skipped and entries continue with R2310.
	R2310	Enter minimum switch-on time t_{ON}	0.3 s 0.1 ... 5.0 s		This field only appears if pulse length is selected in R237.
	R2311	Enter basic load	0 % 0 ... 40 %		When you select the basic load, you enter the desired dosing quantity. 100% basic load would correspond to: – Constantly on for R237 = len – Fmax at R237 = freq (field R239) – 20 mA at R237 = curr
R2 (4)		Configure cleaning function (timer)	LC PV = limit contactor O ₂ (1) LC °C = limit contactor T (2) PID controller (3) Timer (4) Clean = Chemoclean (5)		Cleaning only takes place with one cleaning agent (usually water). By confirming with ENTER, another relay function already switched on is switched off and its settings are reset to the factory settings.

Coding		Field	Setting range (Factory settings, bold)	Display	Info
	R241	Switch function of R2 (4) off or on	Off On		Settings made for the timer are not deleted by switching the function off.
	R242	Enter rinsing/cleaning time	30 s 0 ... 999 s		Settings for Hold and relay are active for this time.
	R243	Enter pause time	360 min 1 ... 7200 min		The pause time is the time between two cleaning cycles (see "Timer for cleaning function" section).
	R244	Enter minimum pause time	120 min 1 ... R243 min		The minimum pause time prevents constant cleaning if a cleaning trigger is present.
R2 (5)		Configure cleaning with Chemoclean (for version with four contacts, Chemoclean option and contacts 3 and 4 assigned)	LC PV = limit contactor O ₂ (1) LC °C = limit contactor T (2) PID controller (3) Timer (4) Clean = Chemoclean (5)		See "Chemoclean function" section. By confirming with ENTER, another relay function already switched on is switched off and its settings are reset to the factory settings.
	R251	Switch function of R2 (5) off or on	Off On		Settings made for the timer are not deleted by switching the function off.
	R252	Select type of start pulse	Int = internal (time-controlled) Ext = external (digital input 2) I+ext = internal + external I+stp = internal, suppressed by external		The cycle for the "int" function is started by the end of the pause time (R257). No real time clock is available. External suppression is required for irregular time intervals (e.g. weekends).
	R253	Enter pre-rinse time	20 s 0 ... 999 s		Rinsing with water takes place.
	R254	Enter cleaning time	10 s 0 ... 999 s		Cleaning with cleaning agent and water takes place.

Coding		Field	Setting range (Factory settings, bold)	Display	Info
	R255	Enter post rinse time	20 s 0 ... 999 s		Rinsing with water takes place.
	R256	Enter number of repeat cycles	0 0 ... 5		R253 ... R255 is repeated.
	R257	Enter pause time	360 min 1 ... 7200 min		The pause time is the time between two cleaning cycles (see "Timer function" section).
	R258	Enter minimum pause time	120 min 1 ... R257 min		The minimum pause time prevents constant cleaning if an external cleaning start is present.
	R259	Enter number of cleaning cycles without cleaning agent (economy function)	0 0 ... 9		After cleaning with cleaner, up to 9 cleaning sessions can be carried out with water only until the next cleaning session with cleaner takes place.

6.4.7 Service

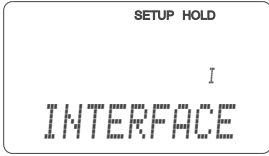
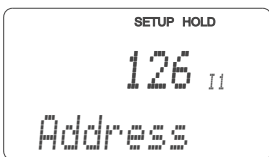
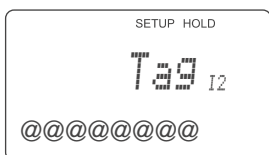
Coding		Field	Setting range (Factory settings, bold)	Display	Info
S		SERVICE function group			Service function settings.
	S1	Select language	ENG = English GER = German FRA = French ITA = Italian NL = Dutch ESP = Spanish		
	S2	Configure Hold	S+C = Hold during configuration and calibration Cal = Hold during calibration Setup = Hold during configuration None = no Hold		S = setup C = calibration

Coding	Field	Setting range (Factory settings, bold)	Display	Info
S3	Manual Hold	Off On		The setting is retained even in the event of a power failure.
S4	Enter Hold dwell period	10 s 0 ... 999 s		
S5	Enter SW upgrade release code (Plus Package)	0000 0000 ... 9999		The code is located on the nameplate. If an incorrect code is entered, you are taken back to the measurement menu. The number is edited with the PLUS or MINUS key and confirmed with the ENTER key. "1" is displayed if the code is active.
S6	Enter SW upgrade release code Chemoclean	0000 0000 ... 9999		The code is located on the nameplate. If an incorrect code is entered, you are taken back to the measurement menu. The number is edited with the PLUS or MINUS key and confirmed with the ENTER key. "1" is displayed if the code is active.
S7	Order number is displayed	OOM253-W		If the device is upgraded, the order code is not automatically adjusted.
S8	Serial number is displayed	4A135705G00		
S9	Reset the device to the basic settings 	No Sens = sensor data Facyt = factory settings		Sens = last calibration is deleted and is reset to factory setting. Facyt = all data (apart from A1 a. S1) are deleted and reset to the factory setting!
S10	Perform device test	No Displ = display test		
S11	Absolute air pressure will be displayed	Current value		Do not compare with the barometer. This shows the relative air pressure (related to sea level).

6.4.8 Service 2

Coding	Field	Setting range (Factory settings, bold)	Display	Note
E	SERVICE 2 function group			Information on the device version
E1	Select module	Contr = controller (1) Trans = transmitter (2) Main = power unit (3) Rel = relay module (4) Sens = sensor (5)		"Sens" only with version WX or WS
	E111 E121 E131 E141 E151	Software version is displayed		If E1 = contr: instrument software If E1 = trans, main, rel: module firmware If E1 = sens: sensor software
	E112 E122 E132 E142 E152	Hardware version is displayed		Only display function
	E113 E123 E133 E143 E153	Serial number is displayed		Only display function
	E114 E124 E134 E144 E154	Module ID is displayed		Only display function

6.4.9 Interfaces

Coding	Field	Setting range (Factory settings, bold)	Display	Info
I	INTERFACE function group			Communication settings (only for device version HART or PROFIBUS).
I1	Enter bus address	Address HART: 0 ... 15 or PROFIBUS: 0 ... 126		Each address may only be given once in a network. If a device address ≠ 0 is selected, the current output is automatically set to 4 mA and the device is set to multi-drop operation.
I2	Display of measuring point			

6.5 Communication

For devices with a communication interface, please also refer to the separate Operating Instructions BA208e00 (HART®) or BA209e00 (PROFIBUS®).

6.6 Calibration

To access the "Calibration" function group, press the CAL key. This function group is used to calibrate and adjust the measuring point. The sensor is calibrated in air or in the medium.



Note!

- At first start-up, sensor calibration of amperometric sensors is absolutely required in order for the measuring system to be able to generate accurate measuring values.
- The optical oxygen sensor OOS61 does not need a calibration at first start-up.
- If the calibration procedure is aborted by pressing the PLUS and MINUS keys at the same time (return to C113 or C124) or if the calibration is faulty, then the previous calibration data are reinstated. A calibration error is indicated by the "ERR" message and flashing of the sensor symbol on the display.
Repeat calibration!
- The instrument is automatically switched to hold during calibration (factory setting).
- After calibration, the system jumps back to the measuring mode. During the hold dwell period the hold symbol is displayed.

The slope calibration of the oxygen sensor OOS61 will be performed in air or in air saturated water. The calibration of the zero point will be performed in nitrogen or in oxygen-free water (water enriched with zero solution). The sensor identifies unassisted the slope calibration (75 ... 140 %SAT) and the calibration of the zero point (0 ... 10 %SAT). No further selection is necessary. These limits are valid for the three types of calibration "air", "water" and "ref".

Coding	Field	Selection or range (factory settings bold)	Display	Info
C	Function group CALIBRATION	Calibration oxygen		Calibration settings.
C1 (1)	Calibration in air	Air (1) H₂O (2) Ref (3)		Calibration in air is only possible if air temperature is ≥ -5 °C (≥ 23 °F).
Remove sensor from the medium and dry completely .				
C111	Start calibration	Last sensor slope Counter in second row counts down: 600 s → 0 s		OOS31/41/71: The sensor slope is checked for 10 s after 530 s (permitted range 75 % ... 140 %, outside range: error E032, calibration is aborted). The stability of the signal is checked during the last 60 s of the calibration (< 1%), if greater: error E044 and calibration is aborted. OOS61: The calibration procedure lasts between 60 and 600 seconds. The stability of the signal (< 1%) and the slope (75 ... 140 %) each of them will be tested for 60 s. If o. k. the data will be transferred, if not, the test starts again. After 600 s the calibration procedure will be aborted and error E032 (slope) or E044 (stability) will be displayed.
C112	Calibration status is displayed	o.k. E xxx		If the calibration status is not o.k., see chapter "System error messages".
Immerse sensor in medium, if C112 = o. k.				If C112 = E xxx, then only no or new . If new, return to C. If yes/no, return to "Measurement".
C113	Store calibration results?	yes no new		If C113 = E xxx, then only no or new . If new, return to C. If yes/no, return to "Measurement".

Coding		Field	Selection or range (factory settings bold)	Display	Info
C1	(2)	Calibration in air-saturated water	Air (1) H₂O (2) Ref (3)		
	Remove sensor from medium and immerse in air-saturated water				
C12	C121	Start calibration	Last sensor slope Counter in second row counts down: 600 s → 0 s		<p>OOS31/41/71: The sensor slope is checked for 10 s after 530 s (permitted range 75 % ... 140 %, outside range: error E032, calibration is aborted). The stability of the signal is checked during the last 60 s of the calibration (< 1%), if greater: error E044 and calibration is aborted.</p> <p>OOS61: The calibration procedure lasts between 60 and 600 seconds. The stability of the signal (< 1%) and the slope (75 ... 140 %) each of them will be tested for 60 s. If o. k. the data will be transferred, if not, the test starts again. After 600 s the calibration procedure will be aborted and error E032 (slope) or E044 (stability) will be displayed.</p>
	C122	Calibration status is displayed	o. k. Exxx		If the calibration status is not o.k., see chapter "System error messages".
	Remove sensor from air-saturated water and reimmerse in medium, if C122 = o. k.				
	C123	Store calibration results?	yes no new		If C122 = E xxx, then only no or new . If new, return to C. If yes/no, return to "Measurement".
C1	(3)	Single-point calibration in medium	Air (1) H ₂ O (2) Ref (3)		<p>The calibration value must be determined using an external method, e. g.:</p> <ul style="list-style-type: none"> • Oxygen handheld measuring device • Winkler titration

Coding		Field	Selection or range (factory settings bold)	Display	Info
	C131	Enter calibration value	Current value		Minimum value is 0.2 mg/l
	C132	Slope is displayed	100.0 % 75.0 ... 140 %		
	C133	Calibration status is displayed	o.k. Exxx		If the calibration status is not o.k., see chapter "System error messages".
	C134	Store calibration results?	yes no new		If C133 = E xxx, then only no or new . If new, return to C. If yes/no, return to "Measurement".

7 Maintenance

Take all the necessary measures in time to guarantee the operational safety and reliability of the entire measuring system.

Maintenance work at the transmitter comprises:

- Calibration (see "Calibration" section)
- Cleaning of assembly and sensor
- Cable and connection check



Warning!

- When carrying out all work on the device, please observe any possible effects on the process control or the process itself.
- When removing the sensor during maintenance or calibration, please consider potential hazards due to pressure, high temperatures and contamination.
- Make sure the device is de-energised before you open it.
If work must be carried out when the device is live, this may only be performed by an electrical technician!
- Switching contacts can be fed by separate circuits. These circuits must also be de-energised before work on the terminals is performed.



Caution ESD!

- Electronic components are sensitive to electrostatic discharge. Personal protective measures such as discharging at the PE beforehand or permanent grounding with a wrist strap are required.
- For your own safety, use only genuine spare parts. With genuine spare parts, the function, accuracy and reliability are also guaranteed after repair.



Note!

If you have any queries, please contact your local Sales Office.

7.1 Maintenance of the entire measuring point

7.1.1 Cleaning the transmitter

Clean the front of the housing with usual commercial cleaning agents.

In accordance with DIN 42 115, the front is resistant to:

- Isopropanol
- Diluted acids (max. 3%)
- Diluted alkalis (max. 5%)
- Esters
- Hydrocarbons
- Ketones
- Household cleaners



Caution!

For cleaning purposes, never use:

- Concentrated mineral acids or alkalis
- Benzyl alcohol
- Methylene chloride
- High-pressure steam

7.1.2 Test variant 1 (DX/DS with OOS41)

Simulation of oxygen measurement

The instrument versions DX/DS work with the sensor OOS41, i.e. with amperometric sensors without a preamp.

To perform a functional test of the instrument, the OOS41 sensor can be simulated by resistors. Since the display value greatly depends on the sensor slope setting and on temperature, the following values should be considered as reference values:

Simulation resistance	Display value
∞ (open)	0 mg O ₂ /l
1.9 M Ω	7 ... 13 mg O ₂ /l
With 1.9 M Ω and a temperature equivalent resistance of 37.3 k Ω after calibration	9.0 ... 9.2 mg O ₂ /l
4.06 M Ω	3 ... 6 mg O ₂ /l

Simulation temperature sensor

The OOS41 sensor uses an NTC sensor (30.0 k Ω /25 °C) for temperature measurement. Use the following equivalent resistances to test the temperature measurement:

Simulation resistance	Display value
95.0 k Ω	0.0 °C (32 °F)
58.7 k Ω	10.0 °C (50 °F)
37.3 k Ω	20.0 °C (68 °F)
30.0 k Ω	25.0 °C (77 °F)
24.3 k Ω	30.0 °C (86 °F)

Test procedure

1. Connect the O₂ equivalent resistance (e. g. decade resistor) to terminals 90 and 91.
2. Connect the temperature equivalent resistance (e. g. decade resistor) to terminals 11 and 12.
3. Air pressure measurement:
The air pressure measured can be checked in field S11 (absolute air pressure). There is no air pressure compensation for the DX version. Use the location altitude setting to compensate for the air pressure influence.

7.1.3 Test variant 2 (WX/WS with OOS31 or OOS71)

Function, simulation and test with OOS31 and OOS71

The instrument versions WX/WS work preferably with the sensors OOS31, OOS31-S and OOS71. These sensors have digital data transfer using the interface RS485. The sensors OOS31 or OOS31-S are automatically recognised internally after calibration. All the sensor data are forwarded to the transmitter by data exchange. After a mains supply interruption, the data are resent to the transmitter. The sensors require a 6.5 .. 8.5 VDC voltage supply from the transmitter.

Due to the digital data, **no simulation** of sensor signals is possible.

Test possibilities in digital mode:

- Measure supply voltage (6.5 ... 8.5 VDC, see connection diagram).
- Connect intact sensor OOS31, OOS31-S oder OOS71.
- Check O₂ measured value and temperature value on transmitter.
- The O₂ input can be tested by measuring the output DC voltage.
The reference is terminal 0, O₂ input is terminal 18:
 - 0 mV = 0.0 mg O₂/l
 - -750 mV = O₂ saturation = 8.1 mg O₂/l (at 25 °C). Value indicated depends on last calibration.
- Measure sensor current consumption (max. ± 5 mA).
- The sensor data can be read off in the fields "Service 2" E151 to E159.
- In measurement mode, the sensor current can be displayed in nA by pressing the PLUS key.
Guide values:
 - OOS31: approx. 40 nA correspond to 1 mg O₂/l at 25 °C
 - OOS31-S: approx. 120 nA correspond to 1 mg O₂/l at 25 °C
 - OOS61: approx. 1300 nA correspond to 8 mg O₂/l at 25 °C
 - OOS71: approx. 800 nA correspond to 1 mg O₂/l at 25 °C

7.1.4 Maintenance oxygen sensors

Please refer to the operating instructions for your sensor with regard to sensor maintenance and trouble-shooting:

OOS31	BA285e00
OOS41	BA284e00
OOS61	BA387e00
OOS71	BA286e00

The operating instructions contain detailed information including:

- Sensor design and function
- Mounting and installation
- Electrical connection
- Start-up and calibration
- Calculation examples and tables for verification of measured values
- Maintenance, regeneration, cleaning
- Trouble-shooting table
- Accessories and spare parts
- Technical data and ordering information

7.1.5 Maintenance assembly

Please refer to the corresponding assembly Operating Instructions for information on maintaining and trouble-shooting the assembly. Here you can find a description for assembling and disassembling, sensor replacement, seal replacement, stability as well as information on spare parts and accessories.

7.1.6 Connecting lines and junction boxes

Since OOS41 works with low measuring currents, shunts in connecting cables and junction boxes may cause considerable inaccuracy.

The following is to be assured:

- Intact gaskets on lids and cable glands
- Dry and clean inner compartment (if necessary dry, clean and insert a dehydrating bag)
- Lines ferrules, terminals and connectors must be free of corrosion
- Terminal screws must be tightened firmly
- Cables must enter junction boxes and instruments from below
- Make a downward cable loop in case of lateral cable entries to allow water to drip off



Note!

If the function test explained in the previous chapter is performed on a junction box instead of the instrument, the junction box, terminals and connecting line to the instrument are automatically included in the test.

OOS31, OOS61 and OOS71 sensors work with a digital interface and therefore are not sensitive to electrical faults and shunting by humidity. Nevertheless, follow the recommendations mentioned above.

7.2 "Optoscope" service tool

The Optoscope together with the "Scopeware" software offers the following possibilities, without having to remove or open the transmitter and without galvanic connection to the instrument:

- Documentation of the instrument settings in conjunction with Commuwin II
- Software update by the service technician
- Upload/download a hex dump to duplicate configurations.

The Optoscope serves as an interface between the transmitter and PC / laptop. The information exchange takes place via the optical interface on the transmitter and via an RS 232 interface on the PC / laptop (see "Accessories").

8 Accessories

8.1 Sensors

- OOS31
oxygen sensor for drinking water and wastewater measurements, SS 1.4571 , potentiostatic amperometric principle
ordering acc. to product structure, see Technical Information (TI285e00)
- OOS41
oxygen sensor for drinking water and wastewater measurements, POM, amperometric principle
ordering acc. to product structure, see Technical Information (TI284e00)
- OOS61
optical oxygen sensor for drinking water and wastewater measurements, SS 1.4571, fluorescence quenching principle
ordering acc. to product structure, see Technical Information (TI387e00)
- OOS71
oxygen sensor for trace measurement, SS 1.4571, potentiostatic amperometric principle
ordering acc. to product structure, see Technical Information (TI286e00)

8.2 Connection accessories

- Measuring cable OMK for oxygen sensors OOS31, OOS61 and OOS71
for use as extension cable between junction box VS and transmitter, not terminated
sold by the metre - order no. 50004124
- Measuring cable CMK for oxygen sensor OOS41
for use as extension cable between junction box VBM and transmitter, not terminated
sold by the metre - order no. 50005374
- VS junction box
with plug-in socket and 7-pole plug,
for cable extension from sensor (OOS71, OOS61, OOS31, OOS3 with SXP connector) to transmitter, IP 65;
order no. 50001054
- Junction box VBM
for cable extension for sensors OOS41, OOS4 (fixed cable versions),
with 10 terminals, IP 65 / NEMA 4X

Cable entry Pg 13.5

Order no. 50003987

Cable entry NPT ½"

Order no. 51500177

8.3 Mounting accessories

- Weather protection cover OYY101 for mounting of field housing, for outdoor installation
material: stainless steel 1.4031;
order no. OYY101-A

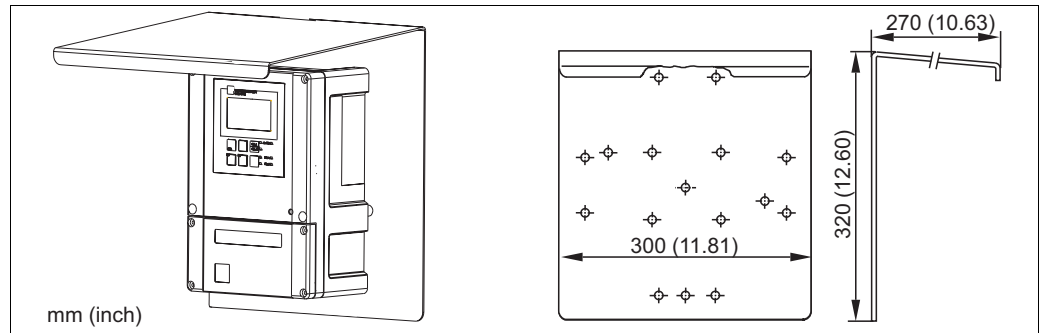


Fig. 41: Weather protection cover for field instrument

a0005585

- Universal upright post OYY102
Square post for mounting of field housing, material: stainless steel 1.4301;
order no. OYY102-A

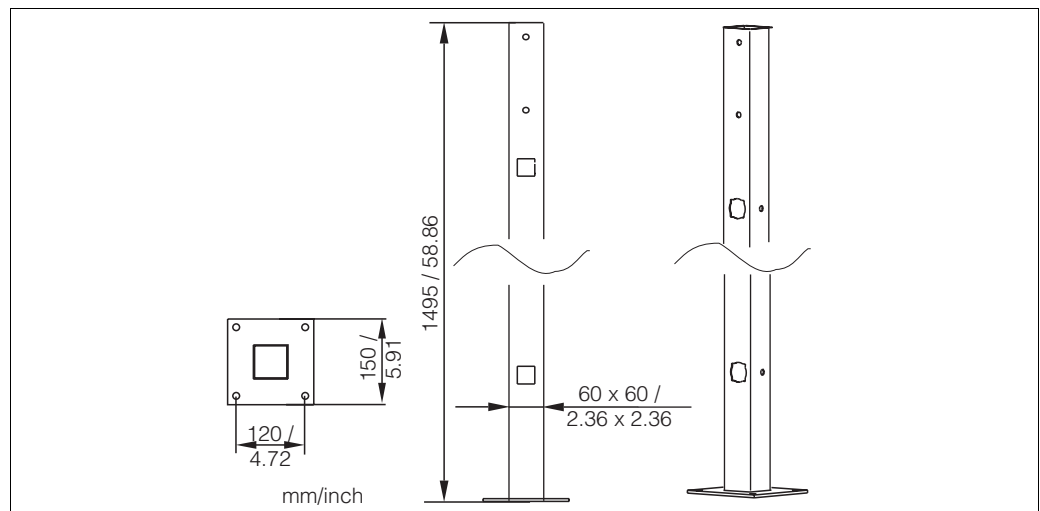


Fig. 42: Square post OYY102

C07-CYY102xx-00-06-00-en-002.eps

- Kit for mounting of field housing on horizontal or vertical pipes (\varnothing max. 60 mm (2.36"))
order no. 50086842

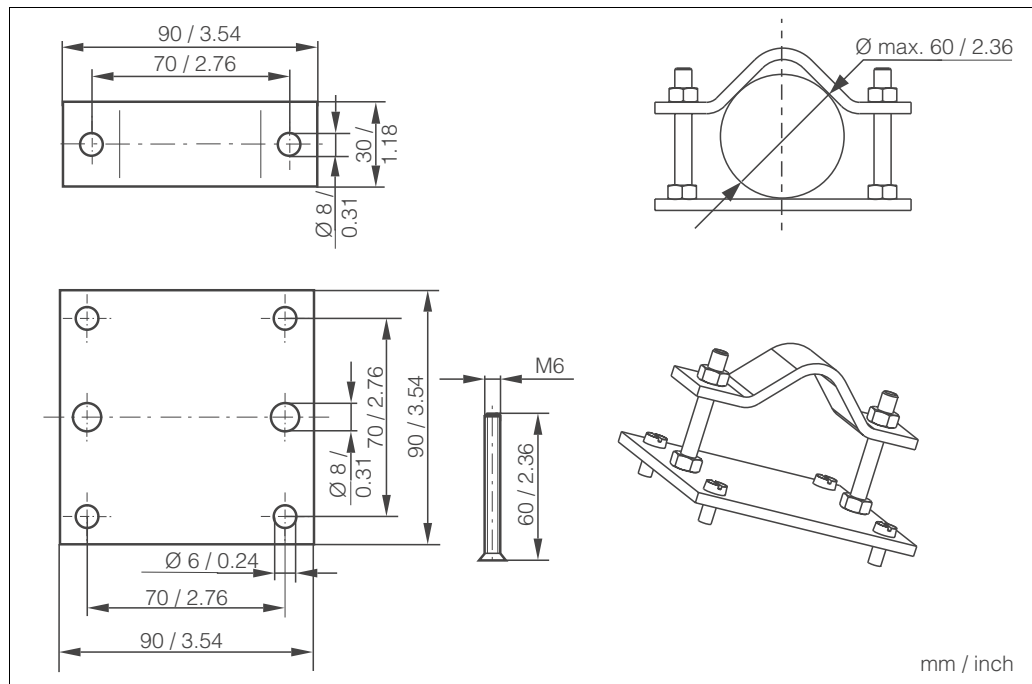


Fig. 43: Pipe mounting kit

8.4 Assemblies

- Flow assembly OOA250
for sensor installation in pipe lines, PVC;
ordering acc. to product structure (Technical Information TI111e00)
- Flow assembly OOA260
for plate or wall mounting, for oxygen trace measurements;
ordering acc. to product structure (Technical Information TI310e00)
- Retractable assembly OOA451
manually driven retractable assembly, stainless steel, with ball valve, for oxygen sensors;
ordering acc. to product structure (Technical Information TI368e00)
- Immersion assembly OOA110
for sensor immersion in the basin, PVC pipe resp. PUR floating body with SS 1.4571 (AISI 316Ti) immersion tube;
Ordering acc. to product structure (see Technical Information TI035e00)
- Immersion assembly OYA611
for sensor immersion in basins, open channels and tanks, PVC;
Ordering acc. to product structure (Technical Information TI166e00)
- Immersion assembly OYY105
for sensor immersion in basins, SS 1.4404 (AISI 316L) pipe, SS 1.4571 (AISI 316Ti) fitting;
Ordering acc. to product structure (Technical Information TI092e00)
- Basin rim holder OYY106
for sensor immersion in basins, SS 1.4301 (AISI 304);
Order no. OYY106-A
- Immersion assembly holder OYH101
for pH, ORP, oxygen, conductivity assemblies and for oxygen and turbidity sensors;
Ordering acc. to product structure (Technical Information TI092e00)

8.5 Software and hardware add-ons

The add-ons can only be ordered by quoting the serial number of the device in question.

- Plus Package
Order no. 51501679
- Chemoclean
Order no. 51500963
- Two-relay card
Order no. 51500320
- Four-relay card
Order no. 51500321
- Two-relay card with current input
Order no. 51504304
- Four-relay card with current input
Order no. 51504305

8.6 Optoscope

- Optoscope
Interface between transmitter and PC / laptop for service purposes.
The Windows software "Scopeware" required for the PC or laptop is supplied with the Optoscope. The Optoscope is supplied in a sturdy plastic case with all the accessories required.
Order no. 51500650

9 Trouble-shooting

9.1 Trouble-shooting instructions

The transmitter constantly monitors its functions itself. If an error occurs which the device recognises, this is indicated on the display. The error number is under the unit display of the main measured value. If more than one error occurs, you can call these up with the MINUS key. Refer to the "System error messages" table for the possible error numbers and remedial measures.

Should a malfunction occur without any transmitter error message, please refer to the "Process-specific errors" or the "Device-specific errors" tables to localise and rectify the error. These tables provide you with additional information on any spare parts required.

9.2 System error messages

The system error messages can be called up and selected with the MINUS key.

Error no.	Display	Tests and/or remedial measures	Alarm contact		Error current		Autom. cleaning start	
			Facty	User	Facty	User	Facty	User
E001	EEPROM memory error	1. Switch device off and then on again.	Yes		No		—	— ¹
E002	Instrument not calibrated, calibration data invalid, no user data, user data invalid (EEPROM error), instrument software not suitable to hardware (controller)	2. Load device software compatible with the hardware (with optoscope, see "Optoscope service tool" section). 3. Load measurement-parameter specific device software. 4. If the error persists, send in the device for repair to your local service organisation or replace the device.	Yes		No		—	— ¹
E003	Download error	Invalid configuration. Repeat download, check optoscope.	Yes		No		No	
E004	Instrument software version not compatible with module hardware version	Load software compatible with hardware. Load measurement-parameter specific device software.	Yes		No		No	
E007	Transmitter malfunction, instrument software not compatible with transmitter version		Yes		No		—	— ¹
E008	Sensor or sensor connection faulty	Check sensor and sensor connection (Service).	Yes		No		—	—
E010	Temperature sensor defective	Send in sensor for repair.	Yes		No		—	—
E017	Sensor electrode section defective	OOS31/41/71: Send in sensor for repair. OOS61: Replace membrane cap, calibrate sensor.	Yes		No		—	—
E018	Sensor membrane damaged (not sealed) or membrane cap not completely screwed on	OOS31/41/71: Replace membrane cap. Completely screw on membrane cap. OOS61: Replace membrane cap during the next preventive maintenance.	Yes		No		—	—
E020	Signal range of sensor undershot	Check medium and sensor.	Yes		No		—	—
E022	Signal range of sensor exceeded	Check medium and sensor.	Yes		No		—	—
E032	During calibration signal outside permitted slope range 75 ... 140 %	Check sensor and recalibrate.	Yes		No		—	— ¹

Error no.	Display	Tests and/or remedial measures	Alarm contact		Error current		Autom. cleaning start	
			Facty	User	Facty	User	Facty	User
E044	During calibration sensor unstable	Check sensor and recalibrate.	Yes		No		No	
E057	Main parameter measuring range exceeded	Check measurement, control and connections.	Yes		No		No	
E059	Below temperature measuring range		Yes		No		No	
E061	Temperature measuring range exceeded		Yes		No		No	
E063	Below current output range 1	Check configuration.	Yes		No		No	
E064	Current output range 1 exceeded	Check measured value and current assignment.	Yes		No		No	
E065	Below current output range 2		Yes		No		No	
E066	Current output range 2 exceeded		Yes		No		No	
E067	Alarm threshold limit contactor 1 exceeded	Check configuration.	Yes		No		No	
E068	Alarm threshold limit contactor 2 exceeded		Yes		No		No	
E069	Alarm threshold limit contactor 3 exceeded		Yes		No		No	
E070	Alarm threshold limit contactor 4 exceeded		Yes		No		No	
E080	Current output 1 range too small	Increase range in "Current outputs" menu.	No		No		—	— ¹
E081	Current output 2 range too small		No		No		—	— ¹
E082	Air pressure range undershot (<500 hPa)	Measurement only possible when uncompensated or with altitude data	Yes		No		No	
E083	Air pressure range exceeded (>1100 hPa)		Yes		No		No	
E100	Current simulation active		No		No		—	— ¹
E101	Service function yes	Switch off service function or switch device off and then on again.	No		No		—	— ¹
E102	Manual mode active		No		No		—	— ¹
E106	Download yes	Wait for download to finish.	No		No		—	— ¹
E116	Download error	Repeat download.	No		No		—	— ¹
E152	Measuring signal of main parameter delayed or frozen (AC function / alternation check)	Inspect sensor and connection line, repair or replace.	Yes		No		No	
E154	Below lower alarm threshold for period exceeding alarm delay	Perform manual comparison measurement if necessary. Service sensor and recalibrate.	Yes		No		No	
E155	Above upper alarm threshold for period exceeding alarm delay		Yes		No		No	
E156	Actual value undershoots alarm threshold (CC setpoint) for longer than the set permissible maximum period		Yes		No		No	
E157	Actual value exceeds alarm threshold (CC setpoint) for longer than the set permissible maximum period		Yes		No		No	
E162	Dosage stop	Check settings in the CURRENT INPUT and CHECK function groups.	Yes		No		No	

Error no.	Display	Tests and/or remedial measures	Alarm contact		Error current		Autom. cleaning start	
			Facty	User	Facty	User	Facty	User
E171	Flow in main stream too low or zero	Restore flow.	Yes		No		No	
E172	Switch-off limit for current input exceeded	Check process variables at sending measuring instrument. Change range assignment if necessary.	Yes		No		No	
E173	Current input < 4 mA	Check process variables at sending measuring instrument.	Yes		No		No	
E174	Current input > 20 mA	Check process variables at sending measuring instrument. Change range assignment if necessary.	Yes		No		No	

1) If this error occurs, there is no possibility of starting a cleaning session (field F8 not applicable with this error).

9.3 Process specific errors

Use the following table to locate and correct errors.

Error	Possible cause	Tests and / or remedial measures	Equipment, spare parts, personnel
Value indicated 0.0	Incorrect sensor	Check sensor type.	OOS41 for OOM2x3-DX/DS. OOS31/71 for OOM2x3-WX/WS.
	Sensor defective	<ul style="list-style-type: none"> – Test with new sensor. – Instrument test with sensor diagram. – Sensor current test. 	Sensor type acc. to instrument version. Sensor simulation see chapter "Maintenance of the entire measuring point".
	Sensor extension line interrupted	Check junction boxes and line.	Sensor simulation see chapter "Maintenance of the entire measuring point".
	Incorrect sensor connection	Check connection.	See chapter "Wiring".
	Instrument input defective	Replace modul MKO1 (DX/DS). Replace modul MKO5 (WX/WS).	See spare parts list.
No or creeping display change	Sensor soiled	Clean sensor membrane.	See instructions for OOSxx. Heavily soiled media: use spray cleaning.
	Sensor installed in dead zone	Check installation conditions, move sensor to area with optimal flow conditions.	
Value indicated too small / sensor can probably not be calibrated	Membrane soiled	Clean sensor membrane.	See instructions for OOSxx. Heavily soiled media: use spray cleaning.
	Incorrect temperature measurement	Check temperature value.	Ref. measurement / thermometer.
	Incorrect altitude setting	Check altitude value.	
	Incorrect air pressure measurement	Check pressure value in field S11. sea level: approx. 1013 hPa. 500 m above sea level: approx. 950 hPa.	Only with version WX/WS/DS. Caution: display value = absolute atmospheric pressure.
	Electrolyte used up or soiled	Replace electrolyte.	See instructions for OOSxx.
	Flow rate too low	Check installation conditions, move sensor to area with optimal flow conditions.	
	Sensor type recognition (OOS31/61/71) unsuccessful	Calibrate sensor to air.	See chapter "Calibration".
	Polarisation incomplete	After sensor commissioning (also after interruption to operation) wait for polarisation time.	Polarisation is complete when the measured value is stable, max. approx. 60 minutes.
Value indicated too high / sensor can probably not be calibrated	Incorrect altitude setting	Check altitude value.	
	Incorrect air pressure measurement	Check pressure value in field S11. sea level: approx. 1013 hPa. 500 m above sea level: approx. 950 hPa.	Only with version WX/WS/DS. Caution: display value = absolute atmospheric pressure.
	Electrolyte or soiled	Replace electrolyte.	See instructions for OOSxx.
	Air cushion under membrane	Install new membrane cap.	For procedures and spare parts ordering see instructions for OOSxx.
	Anode coating worn off (silver coloured)	Sensor regeneration at factory.	Normal anode colour is brownish.
	"S" membrane on standard sensor	Install correct membrane cap.	"S" membrane cap recognisable by white colour (OOS31). With OOS31 self-recognition of S version.
	Sensor type recognition (OOS31/61/71) unsuccessful	Calibrate sensor in air.	See chapter "Calibration".

Error	Possible cause	Tests and / or remedial measures	Equipment, spare parts, personnel
Simulation with sensor incorrect	Incorrect sensor voltage	Required sensor voltage 6.5 ... 8.5 VDC.	See chapter "Function, simulation and test with OOS31 and OOS71".
Fixed incorrect measured value	Impermissible instrument operating state (no response to key actuation)	Switch instrument off and back on.	EMC problem: check line routing. If problem persists, check for possible sources of interference.
Incorrect temperature value	Incorrect sensor connection	Verify connections using connection diagram.	Connection diagram in chapter "Electrical connection".
	Measuring cable defective	Check cable for interruption/short circuit/ shunt.	Ohmmeter or on-site simulation.
	Temp. probe in sensor defective	Measure resistance value in sensor (red and brown sensor lines) only possible with OOS41.	Ohmmeter / values see chapter "Simulation temperature sensor".
Measured value variations	Faults on measuring cable	Connect cable screening according to circuit diagram.	See chapter "Wiring".
	Faults on signal output line	Check line routing, possibly route line separately.	Separate signal output, measuring input and power supply lines.
	Irregular flow/turbulences/large air bubbles	Select a better installation site or calm turbulences. Possibly use large measured value damping factor.	Measured value damping see field A5.
Controller or timer cannot be activated	No relay module available	Install module LSR1-2 or LSR1-4.	
Controller/limit contact does not work	Controller switched off	Activate controller.	See fields R2xx.
	Controller in "Manual/Off" mode	Choose "Auto" or "Manual/On" mode.	Keyboard, REL-key
	Pickup delay setting too long	Disable or shorten pickup delay.	See fields R2xx.
	"Hold" function active	"Automatic Hold" during calibration, "Hold" input activated; "Hold" via keyboard active.	See fields S2 to S4.
Controller/limit contact works continuously	Controller in "Manual/On" mode	Set controller to "Manual/Off" or "Auto".	Keyboard, REL and AUTO keys.
	Dropout delay setting too long	Shorten dropout delay.	See field R2xx.
	Control loop interruption	Check measured value, current output, actuators, chemical supply.	
No O ₂ current output signal	Line open or short-circuited	Disconnect line and measure directly on instrument.	mA meter 0–20 mA.
	Instrument with PROFIBUS PA/DP	PA/DP instruments have no current output.	
Fixed current output signal	Current simulation active	Switch off simulation.	See field O3.
	Impermissible operating state of processor system	Switch instrument off and back on.	EMC problem: check installation, screen, grounding if problem persists.
Incorrect current output signal	Incorrect current assignment	Check current assignment: 0–20 mA or 4–20 mA?	Field O311
	Total load in current loop excessive (> 500 Ω.)	Disconnect output and measure directly on instrument.	mA meter for 0–20 mA DC.
Current output table not accepted	Value interval too small	Select practical intervals.	
No temperature output signal	Instrument does not have 2nd current output	Refer to nameplate for variant; change LSCH-x1 module if necessary.	Module LSCH-x2, see chapter "Spare parts".
	Instrument with PROFIBUS PA	PA instrument has no current output!	
Chemoclean function not available	No relay module (LSR1-x) installed or only LSR1-2 available Additional function not enabled	Install LSR1-4 module. Chemoclean is enabled using the release code supplied by supplier in the Chemoclean retrofit kit.	Module LSR1-4, see chapter "Spare parts".

Error	Possible cause	Tests and / or remedial measures	Equipment, spare parts, personnel
Plus package functions not available	Plus package not enabled (enable with code that depends on serial number and is received from supplier with order of extension package)	<ul style="list-style-type: none"> – When upgrading instrument with Plus package: code received from supplier ⇒ enter. – After replacing defective LSCH/ LSCP module: first enter instrument serial number (s. nameplate) manually, then enter code. 	For a detailed description, see chapter "Replacement of central module".
No HART communication	No central HART module	Verify by looking at nameplate: HART = -xxx5xx and -xxx6xx.	Upgrade to LSCH-H1 / -H2.
	No or wrong DD (device description)	For further information see BA208e00, "HART® - Field communication with OxM223/253".	
	HART interface missing		
	Instrument not registered with HART server		
	Load too low (load > 230 Ω required)		
	HART receiver (e.g. FXA 191) not connected via load but via power supply		
	Incorrect device address (addr. = 0 for single operation, addr. > 0 for multi-drop operation)		
	Line capacitance too high		
	Line interferences		
	Several devices set to same address		
No PROFIBUS® communication	No central PA/DP module	Verify by looking at nameplate: PA = -xxx3xx /DP = xxx4xx.	Upgrade to LSCP module, see chapter "Spare parts".
	Incorrect instrument software version (without PROFIBUS)	For further information, see BA209e00 "PROFIBUS PA/DP - Field communication with OxM223/253".	
	Commuwin (CW) II: Incompatible CW II and instrument software versions		
	No or incorrect DD/DLL		
	Incorrect baud rate setting for segment coupler in DPV-1 server		
	Incorrect station (master) addressed or duplicate address		
	Incorrect station (slaves) address		
	Bus line not terminated		
	Line problems (too long, cross section too small; not shielded, screen not grounded, wires not twisted)		
	Bus voltage too low (bus supply voltage typ. 24 V DC for non-Ex)		

9.4 Instrument specific errors

The following table helps you during the diagnosis and points to any spare parts required.

Depending on the degree of difficulty and the measuring equipment present, diagnosis is carried out by:

- Trained operator personnel
- The user's trained electrical technicians
- Company responsible for system installation/operation
- Responsible Service

Information on the exact spare part designations and on how to install these parts can be found in the "Spare parts" section.

Error	Possible cause	Tests and/or remedial measures	Execution, tools, spare parts
Device cannot be operated, display value 9999	Operation locked	Press CAL and MINUS keys simultaneously.	See "Function of keys" section.
Display dark, no light-emitting diode active	No line voltage	Check whether line voltage is present.	Electrical technician/e.g. multimeter
	Supply voltage wrong/too low	Compare actual line voltage and nameplate data.	User (data for energy supply company or multimeter)
	Connection faulty	Terminal not tightened; insulation jammed; wrong terminals used.	Electrical technician
	Device fuse defective	Compare line voltage and the nameplate data and replace fuse.	Electrical technician/suitable fuse; see drawing in "Spare parts" section.
	Power unit defective	Replace power unit, note variant.	On-site diagnosis by responsible Service, test module necessary
	Central module defective	Replace central module, note variant.	On-site diagnosis by responsible Service, test module necessary
	OOM253: ribbon cable item 310 loose or defective	Check ribbon cable, renew if necessary.	See "Spare parts" section.
Display dark, light-emitting diode active	Central module defective (module: LSCH/LSCP)	Renew central module, note variant.	On-site diagnosis by responsible Service, test module necessary
Display is on but – No change in display and/or – Device cannot be operated – Missing pixels in display	Device or module in device not correctly mounted	OOM223: reinstall module. OOM253: reinstall display module.	Perform with the aid of the installation drawings in the "Spare parts" section.
	Operating system in unpermitted mode	Switch device off and then on again.	Poss. EMC problem: if this persists, check the installation.
	Conductive rubber soiled	Replace LSCxx module. Clean conductive rubber and printed conductor.	Only in emergency, with alcohol and glass fibre brush
	Contact pressure too low	Lay paper strips in frame.	Only in emergency, better: replace LSCxx.
Device gets hot	Voltage wrong/too high	Compare line voltage / nameplate data.	User, electrical technician
	Power unit defective	Replace power unit.	Diagnosis only by responsible Service
Incorrect meas. O ₂ and/or temperature	Transmitter module defective (module: MKO1/MKO5), please first carry out tests and take measures as per the "Process errors without messages" section to make sure that the error is not in the cabling or in the sensor	Measuring input test MKO1: – Connect resistors for oxygen and temperature, see chapter "Simulation oxygen measurement". Measuring input test MKO5: – See chapter "Function, simulation and test with OOS31 and OOS71".	If test negative: replace module (note variant). Perform with the aid of the exploded drawings in the "Spare parts" section. Only possible with intact sensor as digital data transfer sensor <-> instrument. If test positive: check peripherals once more.
	Incorrect sensor current	Sensor current readable in the display in measurement mode by pressing PLUS key 3x.	Display in nA. Nominal value in air for 20 °C and 1013 hPa: 290 nA

Error	Possible cause	Tests and/or remedial measures	Execution, tools, spare parts
Pressure value incorrect / unreadable	Defective pressure sensor	Module MKO1 defective Module MKO5 defective	Pressure readable in field S11 Caution: The absolute air pressure is displayed.
	No pressure sensor available	WX/WS/DS always with pressure sensor DX with MKO1 always without pressure sensor	
Current output, current value incorrect	Adjustment not correct	Check with installed current simulation, connect mA meter directly to current output.	If simulation value incorrect: adjustment in factory or new module LSCxx required. If simulation value correct: check current loop for load and shunts.
	Load too big		
	Shunt/short to ground in current loop		
	Incorrect mode of operation	Check whether 0–20 mA or 4–20 mA is selected.	
No current output signal	Current output stage defective (module LSCH/LSCP)	For safety reasons, first completely disconnect the auxiliary power output. Check with installed current simulation, connect mA meter directly to current output.	If test negative: Renew central module LSCH/LSCP (note variant).
No function of additional relay	OOM253: ribbon cable item 320 loose or defective	Check ribbon cable seating, renew cable if required.	See "Spare parts" section.
Only 2 additional relays can be triggered	Relay module LSR1-2 installed with 2 relays	Upgrade to LSR1-4 with 4 relays.	User or responsible Service
Additional functions (Plus package) missing	No or incorrect release code used	If retrofitting: check whether the correct serial number was quoted when ordering the Plus package.	Handled by your supplier
	Incorrect device serial number saved in LSCH/LSCP module	Check whether serial number on the nameplate matches SNR in LSCH/LSCP (field E112).	The serial number of the device is definitive for the Plus package.
	Changed product strategy	From introduction WX/WS: – WX/WS/DS always with pressure sensor – DX always without pressure sensor	For DS: Use altitude setting.
Additional functions (Plus package and/or Chemoclean) missing after LSCH/LSCP module replaced	Replacement modules LSCH or LSCP have the device serial number 0000 when they leave the factory. The Plus package or Chemoclean are not enabled on leaving the factory.	In the case of LSCH/LSCP with SNR 0000, a device serial number can be entered once in fields E114 to E116. Then enter the release code for the Plus package and/or Chemoclean.	For a detailed description, see "Replacing central module" section.
No HART or PROFIBUS-PA/DP interface function	Incorrect central module	HART: LSCH-H1 or H2 module, PROFIBUS-PA: LSCP-PA module, PROFIBUS-DP: LSCP-DP module, see field E112.	Replace central module; user or responsible Service.
	Wrong software	SW version see field E111.	SW can be modified with optoscope.
	Bus problem	Remove some devices and repeat the test.	Contact responsible Service.
No sensor data in E151 ... E159	Analog sensor connected	For OOS3 and compatible sensors, no data exchange possible	

9.5 Spare parts

Spare parts are to be ordered from your sales center responsible. Specify the order numbers listed in the chapter "Spare parts kits".

To be on the safe side, you should **always** specify the following data with your spare part orders:

- Instrument order code (order code)
- Serial number (serial no.)
- Software version where available

Refer to the nameplate for the order code and serial number.

The software version is displayed in the instrument software (see chapter "Instrument configuration") if the instrument processor system is functional.

9.5.1 Dismantling the panel mounted instrument

Caution!

Please note the effects on the process if the device is taken out of service!

Note!

Please refer to the following diagram for the item numbers.

1. Disconnect the terminal block (item 424 b) from the rear of the device to de-energise the device.
2. Then remove the terminal blocks (item 424 a and poss. 430) from the rear of the device. Now you can disassemble the device.
3. Press in the latches of the end frame (item 340) and remove the frame from the rear.
4. Release the special screw (item 400) by turning it counter-clockwise.
5. Remove the entire electronics block from the housing. The modules are only mechanically connected and can be easily separated:
 - Simply remove the processor/display module from the front.
 - Pull out the brackets of the rear plate (item 320) slightly.
 - Now you can remove the side modules.
6. Remove the O₂ transmitter (item 250/260) as follows:
 - Using fine side-cutting pliers, nip off the heads of the synthetic distance holders.
 - Then remove the module from above.

Assembly is the reverse of the disassembly sequence. Tighten the special screw hand-tight without a tool.



9.5.2 Panel mounted instrument

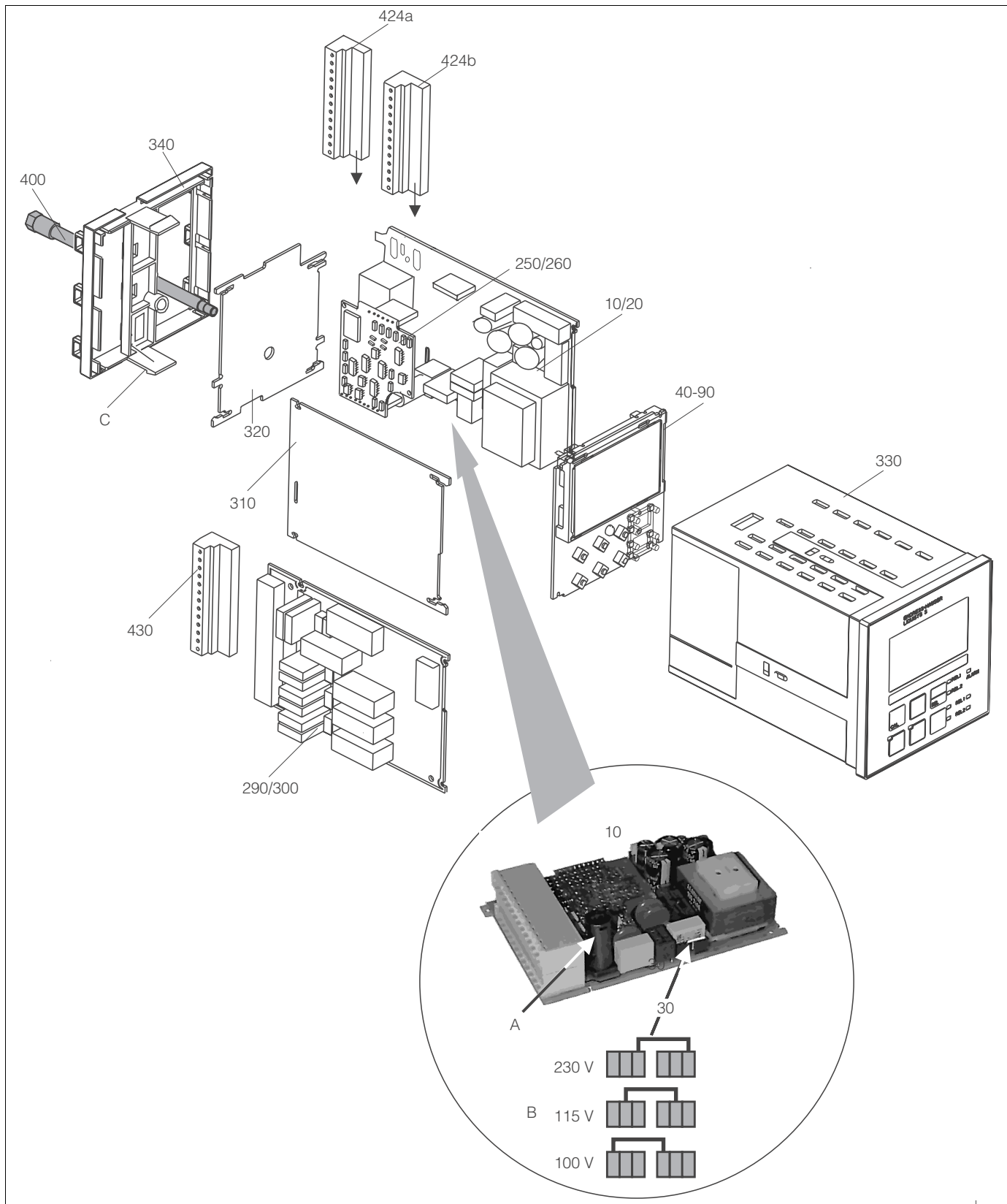


Fig. 44: Exploded drawing of panel mounted instrument

The exploded drawing contains the components and spare parts of the panel-mounted instrument. You can take the spare parts and the corresponding order number from the following section using the item numbers.

C07-00M223xx-09-06-00-xx-001.eps

Item	Kit description	Name	Function/contents	Order number
10	Power unit (main module)	LSGA	100 / 115 / 230 V AC	51500317
20	Power unit (main module)	LSGD	24 V AC + DC	51500318
30	Jumper		Part of power unit item 10	
40	Central module (controller)	LSCH-S1	1 current output	51501225
50	Central module (controller)	LSCH-S2	2 current outputs	51501222
60	Central module (controller)	LSCH-H1	1 current output + HART	51501223
70	Central module (controller)	LSCH-H2	2 current outputs + HART	51501226
80	Central module (controller)	LSCP-PA	PROFIBUS PA/no current output	51501227
90	Central module (controller)	LSCP-DP	PROFIBUS DP/no current output	51502500
250	O ₂ transmitter	MKO1 (-DX/DS)	O ₂ + temperature O ₂ + temperature + air pressure	51501207 51501208
260	O ₂ transmitter	MKO5 (-WX/WS)	O ₂ + temperature + air pressure	51506938
290	Relay module	LSR1-2	2 relays	51500320
290	Relay module	LSR2-2i	2 relays + current input 4 ... 20 mA	51504304
300	Relay module	LSR1-4	4 relays	51500321
300	Relay module	LSR2-4i	4 relays + current input 4 ... 20 mA	51504305
310	Side panel		Kit with 10 parts	51502124
310, 320, 340, 400	Housing mechanical parts		Rear plate, side panel, end frame, special screw	51501076
330, 400	Housing module		Housing with front membrane, sensory tappets, gasket, special screw, tensioning dogs, connection plates and nameplates	51501075
340	End frame PROFIBUS-DP		Rear frame for PROFIBUS DP, with D-submin plug connector	51502513
345	Grounding terminal strip		PE and screening connections	51501086
424a, 424b	Terminal strip set Standard + HART / DX + DS		Complete terminal strip set, standard + HART	51501204
424a, 424b	Terminal strip set PROFIBUS PA / DX + DS		Complete terminal strip set, PROFIBUS PA	51502127
424a, 424b	Terminal strip set PROFIBUS DP / DX + DS		Complete terminal strip set, PROFIBUS DP	51502492
430	Terminal strip		Terminal strip for relay module	51501078
A	Fuse		Part of power unit, item 10	
B	Choice of line voltage		Position of jumper on power unit, item 10 depending on line voltage	
C	End frame latches		Part of the end frame	

9.5.3 Dismantling the field instrument



Caution!

Please note the effects on the process if the device is taken out of service!



Note!

Please refer to the following diagram for the item numbers.

To dismantle the field instrument you need the following tools:

- Standard set of screwdrivers
- Torx-screwdriver size TX 20

Proceed as follows:

1. Open and remove the cover of the connection compartment (item 420).
2. Disconnect the mains terminal (item 470) to de-energise the device.
3. Open the display cover (item 410) and loosen the ribbon cables (item 310/320) on the side of the central module (item 40 ... 90).
4. To remove the central module (item 40), loosen the screw in the display cover (item 450 b).
5. Proceed as follows to remove the electronics box (item 330):
 - Release the screws in the housing base (item 450 a) with two revolutions.
 - Then push the entire box backwards and remove it from above.
 - Make sure that module locks do not open!
 - Loosen the ribbon cables (item 310/320).
 - Bend the module locks out and remove the modules.
6. To remove the docking module (item 340), remove the screws in the housing base (item 450 c) and remove the entire module from above.
7. Proceed as follows to remove the O₂ transmitter (item 250/260):
 - Using fine side-cutting pliers, nip off the heads of the synthetic distance sleeves.
 - Then remove the module from above.

To assemble, carefully push the modules into the trolley tracks of the electronics box and let them engage in the side box noses.



Note!

- Incorrect mounting is not possible. Modules inserted in the electronics box incorrectly are not operable since the ribbon cables cannot be connected.
- Make sure the cover seals are intact to guarantee IP 65 ingress protection.

9.5.4 Field instrument

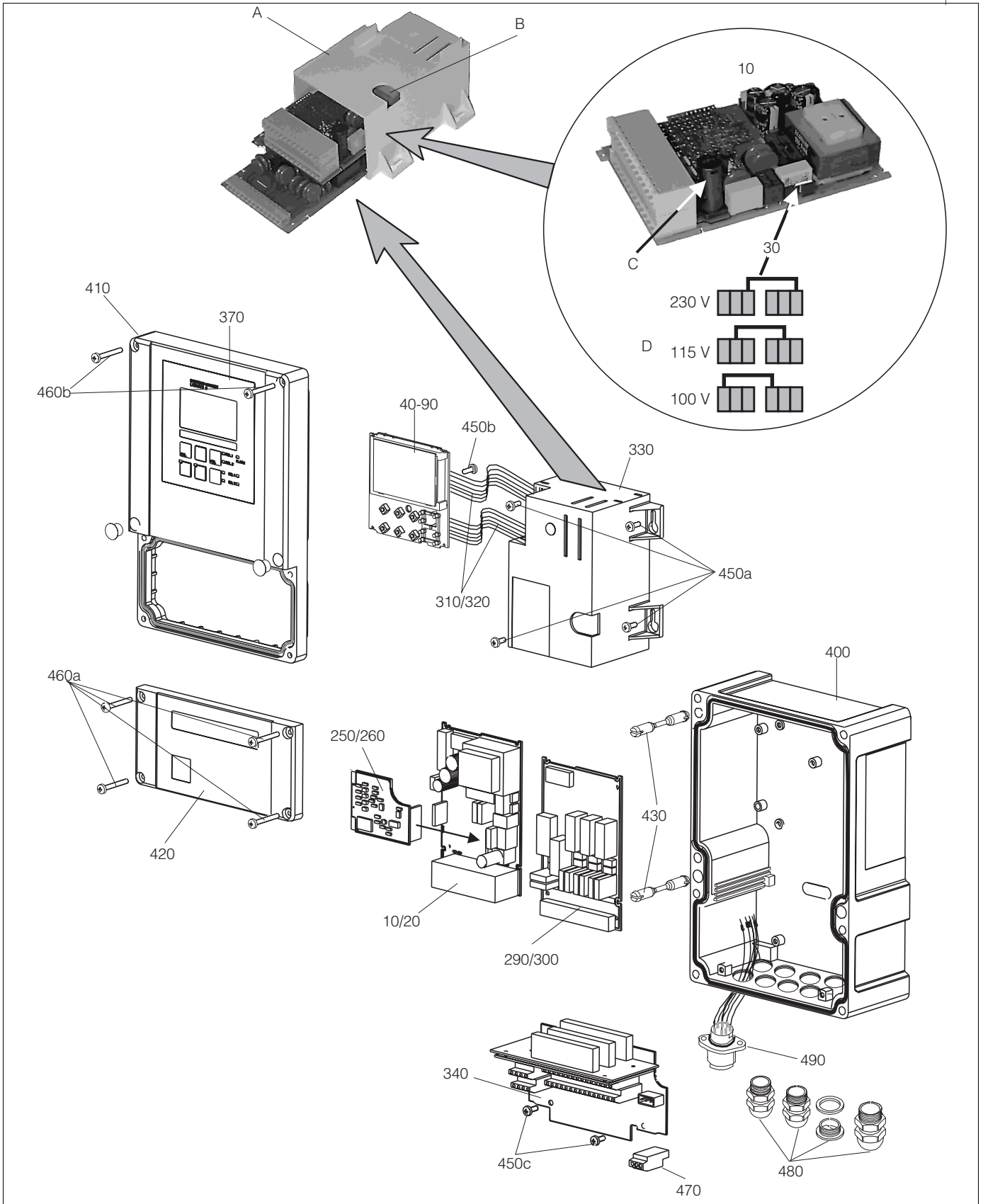


Fig. 45: Exploded drawing of field instrument

C07-OOM253xx-09-06-00-xx-001.eps

The exploded drawing contains the components and spare parts of the field device. You can take the spare parts and the corresponding order number from the following section using the item numbers.

Item	Kit description	Name	Function/contents	Order number
10	Power unit (main module)	LSGA	100 / 115 / 230 V AC	51500317
20	Power unit (main module)	LSGD	24 V AC + DC	51500318
30	Jumper		Part of power unit item 10	
40	Central module (controller)	LSCH-S1	1 current output	51501225
50	Central module (controller)	LSCH-S2	2 current outputs	51501222
60	Central module (controller)	LSCH-H1	1 current output + HART	51501223
70	Central module (controller)	LSCH-H2	2 current outputs + HART	51501226
80	Central module (controller)	LSCP	PROFIBUS PA/no current output	51501227
90	Central module (controller)	LSCP-DP	PROFIBUS DP/no current output	51502500
250	O ₂ transmitter	MKO1 (-DX/DS)	O ₂ + temperature O ₂ + temperature + air pressure	51501207 51501208
260	O ₂ transmitter	MKO5 (-WX/WS)	O ₂ + temperature + air pressure	51506938
290	Relay module	LSR1-2	2 relays	51500320
290	Relay module	LSR2-2i	2 relays + current input 4 ... 20 mA	51504304
300	Relay module	LSR1-4	4 relays	51500321
300	Relay module	LSR2-4i	4 relays + current input 4 ... 20 mA	51504305
310, 320	Ribbon cable lines		2 ribbon cable lines	51501074
330, 340, 450	Internal housing parts		Docking assembly, empty electronics box, small parts	51501073
450a, 450c	Torx screws K4x10		Internal housing parts	
450b	Torx screw for central module		Internal housing parts	
370, 410, 420, 430, 460	Housing cover		Display cover, connection compartment cover, front membrane, hinges, cover screws, small parts	51501068
460a, 460c	Screws for housing cover		Parts of housing cover	
400, 480	Housing base		Base, threaded joints	51501072
430	Hinges		2 pairs of hinges	51501069
470	Terminal strip		Terminal strip for connection to mains	51501079
490	Sensor socket SXB		Sensor connection	51506966
A	Electronics box with relay module LSR1-x (bottom) and power unit LSGA/LSGD (top)			
B	Fuse also accessible if electronics box installed			
C	Fuse		Part of power unit, item 10	
D	Choice of line voltage		Position of jumper on power unit, item 10 depending on desired line voltage	



9.5.5 Replacing the central module

Note!

Generally, when a central module has been replaced, all data which can be changed are set to the factory setting.

Proceed as described below if a central module is replaced:

1. If possible, note the customised settings of the device, such as:
 - Calibration data
 - Current assignment, main parameter and temperature
 - Relay function selections
 - Limit value/controller settings
 - Cleaning settings
 - Monitoring functions
 - Interface parameters
2. Disassemble the device as explained in the "Dismantling the panel-mounted instrument" or "Dismantling the field instrument" section.
3. Use the part number on the central module to check whether the new module has the same part number as the previous module.
4. Assemble the device with the new module.
5. Start up the device again and check the basic functions (e.g. measured value and temperature display, operation via keyboard).
6. Enter the serial number:
 - Read the serial number ("ser-no.") off the nameplate of the device.
 - Enter this number in the fields E115 (year, one-digit), E116 (month, one-digit), E117 (cons. number, four-digit).
 - In the field E118, the complete number is displayed again so you can check it is correct.



Caution!

You can only enter the serial number for modules fresh from the factory with the serial number 0000. This can only be done **once!** For this reason, make sure the number entered is correct before you confirm with ENTER!

Entry of an incorrect code will prevent the additional functions from being enabled. An incorrect serial number can only be corrected at the factory!

Press ENTER to confirm the serial number or cancel the entry to enter the number again.

7. If available, enter the release codes for the Plus Package and/or Chemoclean in the "Service" menu.
8. Check the Plus Package release (e.g. by opening the function group CHECK / Code P) or the Chemoclean function.
9. Make the customer device settings again.

9.6 Return

If the transmitter has to be repaired, please return it *cleaned* to the sales centre responsible. Please use the original packaging, if possible.

9.7 Disposal

The device contains electronic components and must therefore be disposed of in accordance with regulations on the disposal of electronic waste.

Please observe local regulations.

10 Technical data

10.1 Input

Measured variable	Oxygen Temperature	
Measuring range	Oxygen:	
	OOS31:	
	– Oxygen concentration	0 ... 20 / 0 ... 60 mg/l
	– Oxygen saturation index	0 ... 200 / 0 ... 600 % SAT
	– Oxygen partial pressure	0 ... 400 / 0 ... 1200 hPa
	OOS41/61:	
	– Oxygen concentration	0 ... 20 mg/l
	– Oxygen saturation index	0 ... 200 % SAT
	– Oxygen partial pressure	0 ... 400 hPa
	OOS71:	
	– Oxygen concentration	0 ... 20 mg/l
	– Oxygen saturation index	0 ... 200 % SAT
	– Oxygen partial pressure	0 ... 400 hPa
	Temperature:	-10 ... 60 °C (14 ... 140 °F)
Cable specification	Cable length:	
	– OOS 31, OOS 71	max. 100 m (328 ft)
	– OOS 41	max. 50 m (164 ft)
O₂ signal input	– Version DX/DS:	0 ... 3000 nA
	– Version WX/WS:	digitale communication or 0 ... -7500 mV
Binary inputs 1 and 2	Voltage:	10 ... 50 V
	Current consumption:	max. 10 mA
Current input	4 ... 20 mA, galvanically isolated	
Load	Load: 260 Ω for 20 mA (voltage drop 5.2 V)	

10.2 Output

Output signal	0/4 ... 20 mA, galvanically isolated, active	
Signal on alarm	2.4 or 22 mA in case of an error	
Load	max. 500 Ω	
Transmission range	Oxygen:	
	OOS31:	
	– Oxygen concentration	Δ 0.2 ... Δ 20 / Δ 0.6 ... Δ 60 mg/l
	– Oxygen saturation index	Δ 2 ... Δ 200 / Δ 6 ... Δ 600 % SAT
	– Oxygen partial pressure	Δ 4 ... Δ 400 / Δ 12 ... Δ 1200 hPa
	OOS41/61:	
	– Oxygen concentration	Δ 0.2 ... Δ 20 mg/l
	– Oxygen saturation index	Δ 2 ... Δ 200 % SAT
	– Oxygen partial pressure	Δ 4 ... Δ 400 hPa
	OOS71:	
	– Oxygen concentration	Δ 0.02 ... Δ 20 mg/l
	– Oxygen saturation index	Δ 0.2 ... Δ 200 % SAT
	– Oxygen partial pressure	Δ 0.4 ... Δ 400 hPa
	Temperature:	Δ 7 ... Δ 70 °C
Signal resolution	max. 700 Digits/mA	
Insulation voltage	max. 350 V _{eff} / 500 V DC	

Overvoltage protection	according to EN 61000-4-5	
Auxiliary voltage output	Output voltage:	15 V ± 0,6 V
	Output current:	max. 10 mA
Contact outputs (floating changeover contacts)	Switching current with ohmic load (cos φ = 1):	Max. 2 A
	Switching current with inductive load (cos φ = 0.4):	Max. 2 A
	Switching voltage:	Max. 250 V AC, 30 V DC
	Switching capacity with ohmic load (cos φ = 1):	Max. 500 VA , 60 W DC
	Switching capacity with inductive load (cos φ = 0.4):	Max. 500 VA
Limit contactor	Pick-up/drop-out delay	0 ... 2000 s
Controller	Function (adjustable):	Pulse length/pulse frequency controller
	Controller behaviour:	P, PI, PD, PID
	Control gain K_p :	0.01 ... 20.00
	Integral action time T_n :	0.0 ... 999.9 min
	Derivative action time T_v :	0.0 ... 999.9 min
	Period length for pulse length controller:	0.5 ... 999.9 s
	Frequency for pulse frequency controller:	60 ... 180 min ⁻¹
	Basic load:	0 ... 40% of max. set value
Alarm	Function (switchable):	Latching/momentary contact
	Alarm threshold adjustment range:	O ₂ , temperature: entire measuring range, depending on sensor type
	Alarm delay:	0 ... 2000 s (min)
	Monitoring time lower limit violation:	0 ... 2000 min
	Monitoring time upper limit violation:	0 ... 2000 min

10.3 Power supply

Supply voltage	Depending on ordered version: 100/115/230 V AC +10/-15 %, 48 ... 62 Hz 24 V AC/DC +20/-15 %
Power consumption	Max. 7.5 VA
Mains fuse	Fine-wire fuse, semi-delay 250 V/3.15 A

10.4 Performance characteristics

Measured value resolution	Oxygen: – OOS31/41/61: – OOS71:	0.01 mg/l / 0.1 % SAT / 1 hPa 0.001 mg/l / 0.1 % SAT / 1 hPa
	Temperature:	0.1 °C
Maximum measured error¹	Display – Oxygen: – Temperature:	max. 0.5 % of measuring range max. 1.0 % of measuring range
	Signal output – Oxygen: – Temperature:	max. 0.75 % of measuring range max. 1.25 % of measuring range
Repeatability¹	max. 0.2 % of measuring range	
Temperature compensation range	0 ... 50 °C (32 ... 122 °F)	
Pressure compensation range	500 ... 1100 hPa	
Altitude adjustment range	0 ... 4000 m (0 ... 13124 ft)	
Salinity adjustment range	0 ... 4 ‰	
Slope adjustment range	OOS31:	75 ... 140 % (nominal 290 nA, in air, 20 °C (68 °F), 1013 hPa)
	OOS41:	75 ... 140 % (nominal 290 nA, in air, 20 °C (68 °F), 1013 hPa)
	OOS71:	50 ... 150 % (nom. 8000 nA, in air, 20 °C (68 °F), 1013 hPa)

1) in accordance with IEC 746-1, for nominal operating conditions

10.5 Environment

Ambient temperature range	-10 ... +55 C (+14 ... +131 °F)	
Ambient temperature limits	-20 ... +60 C (-4 ... +140 °F)	
Storage temperature	-25 ... +65 C (-13 ... +149 °F)	
Electromagnetic compatibility	Interference emission and interference immunity as per EN 61326: 1997 / A1: 1998	
Overvoltage protection	As per EN 61000-4-5:1995	For outputs, binary inputs and current input
	Degree of protection	Panel-mounted instrument: Field device:
Relative humidity	10 ... 95%, not condensating	

10.6 Mechanical construction

Design/dimensions	Panel-mounted instrument:	L x W x D: 96 x 96 x 145 mm (3.78" x 3.78" x 5.71") Installation depth: approx. 165 mm (6.50")
	Field device:	L x W x D: 247 x 170 x 115 mm (9.72" x 1.70" x 4.53")
Weight	Panel-mounted instrument:	Max. 0.7 kg (1.5 lb)
	Field device:	Max. 2.3 kg (5.1 lb)
Material	Panel-mounted instrument housing:	Polycarbonate
	Field housing:	ABS PC Fr
	Front membrane:	Polyester, UV-resistant
Terminals	Cable cross-section:	max. 2.5 mm ²

11 Appendix

Operating matrix OOM223/253 - DX/DS with OOS41 - WX/WS with OOS61

CALIBRATION C	Ref = entry of reference value C1 (3)	Entry of calibration value current value C131	Slope is displayed 100.0 % 75.0 ... 140.0 % C132	Calibration status is displayed o.k. Exxx C133	Store calibration results yes; no; new C134
	H ₂ O = water C1 (2)	Start calibration Countdown 600 s --> 0 s C121	Calibration status is displayed o.k. Exxx C122	Store calibration results yes; no; new C123	
	on air C1 (1)	Start calibration Countdown 600 s --> 0 s C111	Calibration status is displayed o.k. Exxx C112	Store calibration results yes; no; new C113	
MEAS. VAL. DISPLAY with TEMPERATURE DISPLAY in °C Edit: Code 22 Read: any code	+	Temperature display in °F	Temperature display suppressed	Measured value in mg/l	Measured value in % Sat
		-	1st error is displayed (if present)	Other errors are displayed (up to max. 10 errors)	
SETUP 1 A	Selection of operating mode mg/l % SAT hPa A1	Selection of display unit mg/l ppm ppb A2	* ----- A3	Entry of altitude 0 m 0 ... 4000 m A4	Entry of measured value damping 1 (no damping) 1 ... 60 A5
	Entry of salt concentration 0.0 % 0.0 ... 4.0 % B1	Entry of process temperature current meas. value -10.0 ... 60.0 °C B2	Display of temp. difference (Offset) current offset -5.0 ... +5.0 °C B3	* these fields are not available with DX versions	
CURRENT INPUT Z	Controller switch-off by current input Off: Input Z1	Delay for controller switch-off by current input 0 s 0 ... 2000 s Z2	Delay for controller switch-on by current input 0 s 0 ... 2000 s Z3	Switch-off limit value for current input 50% 0 ... 100% Z4	Switch-off direction for current input Low; High Z5
			Tab = Table O3 (3)	Selection of table option read edit O331	Enter number of value pairs in table 1 1 ... 10 O332
CURRENT OUTPUT O	Selection of current output Out 1, Out 2 O1	Select meas. unit for 2nd current output °C; mg/l; % Sat, hPa; Contr O2	lin = linear O3 (1)	Selection of current range 4-20 mA; 0-20 mA O311	Enter 0/4mA value 0.00 mg/l; 0...20 mg/l 0.0%Sat; 0...200% Sat 0 hPa; 0...400 hPa 0.0 °C; -10...60 °C O312
			sim = Simulation O3 (2)	Entry of simulation value current value 0 ... 22.00 mA O321	
ALARM F	Selection of contact type LATCH=latching Momen=momentary F1	Selection of alarm delay unit min; s F2	Alarm delay 0 min (s) 0 ... 2000 min (s) (depends on F2) F3	Setting of error current 22 mA; 2.4 mA F4	Selection of error number 1 1 ... 255 F5
	Selection of alarm threshold monitoring Off; Low; High; Lo+Hi=low and high P1	Alarm delay 0 min (s) 0 ... 2000 min (s) (depends on F2) P2	Setting of lower alarm threshold 0.00 mg/l; 0...19 mg/l 0.0%SAT; 0...190%SAT 0 hPa; 0...380 hPa P3	Setting of upper alarm threshold 20.00 mg/l; 1...20 mg/l 200.0%SAT; 10...200%SAT 400 hPa; 20...400hPa P4	Selection of process monitoring off; AC; CC monitoring limit (AC): AC+CC ±0.1 mg/l ±1 % SAT ±2 hPa (in 1 h) P5

Measured value in hPa	Measured value Sensor signal in nA / mV	Measured value Current input in %	Measured value Current input in mA
--------------------------	--	--------------------------------------	---------------------------------------

only display switch!!

Selection of measuring range
20 mg/l 60 mg/l
200%Sat 600% Sat
400 hPa 1200 hPa
A6

Feedforward control to PID controller Off ; lin = linear Basic = basic load Z6	Feedforward control gain = 1 at 50% 0 ... 100% Z7	Selection of value pair in table 1 1 ... no. of value pairs assign O333	Entry of x-value (measured value) 0.00 mg/l ; 0...20 mg/l 0.0%SAT ; 0...200%SAT 0 hPa ; 0...400 hPa O334	Entry of y-value (current) 0.00mA ; 0...20.00mA O335	Table status o.k. yes; no O336
--	--	---	--	---	---

Enter 20mA value
10.00 mg/l ; 0...20 mg/l
100.0%SAT ; 0...200%SAT
200 hPa ; 0...400hPa
40.0 °C ; -10...60 °C
O313

Activate alarm contact yes; no F6	Activate error current for previously set error no; yes F7	Automatic start of cleaning function no; yes F8	Selection "next error" or return to menu Next=next error <--- R F9
--	---	--	--

Setting of maximum permissible limit violation period (below limit) 480 min ; 0...2000 min P6	Setting of maximum permissible limit violation period (upper limit) 240 min ; 0...2000 min P7	Setting of limit value 5.00 mg/l ; 0...20 mg/l 50.0 %SAT ; 0...200%SAT 200 hPa ; 0...400 hPa P8
--	--	---

Field for customer settings

RELAY R	Clean = Chemoclean (with Rel3 a. Rel4 only) R2 (5)	Function R2 (5) switch on or off Off On R251	Selection of start pulse int = internal i+ext = internal + external ext = external i+stp = internal suppressed by external R252		
	Timer R2 (4)	Function R2 (4) switch on or off Off On R241	Setting of rinse time 30 s 0 ... 999 s R242	Setting of pause time 360 min 1 ... 7200 min R243	
	PID controller R2 (3)	Function R2 (3) switch on or off Aus; Ein; Basic; PID+B R231	Entry of set point 5,00 mg/l; 0...20 mg/l 50,0 %SAT; 0...200%SAT 200 hPa; 0...400 hPa R232	Entry of control gain K _p 1.00 0.01 ... 20.00 R233	
	LC °C = limit contactor T R2(2)	Function R2 (2) switch on or off Off On R221	Entry of switch-on temperature 60 °C -10 ... 60 °C R222	Entry of switch-off temperature 60 °C -10 ... 60 °C R223	
	Select contact to be configured Rel1; Rel2; Rel3; Rel4 R1	Function R2 (1) switch on or off Off On R211	LC PV = limit contactor O ₂ R2(1)	Select switch-on contact point 20,00 mg/l; 0...20 mg/l 200,0%SAT; 0...200%SAT 400 hPa; 0...400 hPa R212	Select switch-off contact point 20,00 mg/l; 0...20 mg/l 200,0%SAT; 0...200%SAT 400 hPa; 0...400 hPa R213
SERVICE S	Select contact to be configured Eng; Ger; Ita; Fra; Esp; Nel S1	Hold configuration none = no hold Cal = during calibration S+C = during setup + calibration Setup = during setup S2	Manual hold Off On S2	Entry of hold dwell period 10 s 0 ... 999 s S3	
SERVICE 2 E	***** E1 (5)	***** E151	***** E152	***** E153	***** E154
	Rel = relay E1 (4)	Software version SW version E141	Hardware version HW version E142	Serial number is displayed E143	Module ID is displayed E144
	MainB = main board E1 (3)	Software version SW version E131	Hardware version HW version E132	Serial number is displayed E133	Module ID is displayed E134
	Trans = transmitter E1 (2)	Software version SW version E121	Hardware version HW version E122	Serial number is displayed E123	Module ID is displayed E124
	Contr = controller E1 (1)	Software version SW version E111	Hardware version HW version E112	Serial number is displayed E113	Module ID is displayed E114
INTERFACE F	Entry of address Hart: 0 ... 15 or PROFIBUS: 1...126 F1	Tag description @@@@@@@@ F2			

Entry of pre-rinse time 30 s 0 ... 999 s R253	Entry of cleaning time 10 s 0 ... 999 s R254	Entry of post-rinse time 30 s 0 ... 999 s R255	Number of repeat cycles 0 0 ... 5 R256	Setting of interval between 2 cleaning cycles (pause time) 360 min 1...7200 min R257	Setting of minimum pause time 120 min 1...3600 min R258	Number of cleaning cycles without cleaning agent 0 0 ... 9 R259	Chemoclean: uses 2 contacts, only permissible for contacts 3 (+4)		
Setting of minimum pause time 120 min 1...3600 min R244									
Entry of integral action time Tn (0,0=no I component) 0,0 s 0,0...999,9 min R234	Entry of derivative action time Tv (0,0=no D component) 0,0 s 0,0...999,9 min R235	Selection of control characteristics inv = invers dir = direct R236	Selection len = pulse length freq = pulse frequency curr = current output R237	Entry of pulse interval 10,0 s 0,5...999,9 s R238	Entry of pulse frequency 120 min⁻¹ 60 ... 180 min ⁻¹ R239	Entry of minimum on time t _{on} 0,3 s 0,1 ... 5,0 s R2310	Entry of basic load 0% 0 ... 40% R2311		
Setting of pick-up delay 0 s 0 ... 2000 s R224	Setting of drop-out delay 0 s 0 ... 2000 s R225	Setting of alarm threshold (absolute value) 60 °C -10 ... 60 °C R226	LC status MIN; MAX R227						
Setting of pick-up delay 0 s 0 ... 2000 s R214	Setting of drop-out delay 0 s 0 ... 2000 s R215	Setting of alarm threshold (abs. value) 20,00 mg/l; 0...20 mg/l 200,0%SAT; 0...200%SAT 400 hPa; 0...400 hPa R216	LC status MIN; MAX R217						
Entry of SW upgrade release code (Plus package) 0000 0000 ... 9999 S2	Entry of SW upgrade release code Chemoclean 0000 0000 ... 9999 S6	Display of order number S7	Display of serial number S8	Reset instrument to default values no; sens: factory S9	Perform instrument test no; display S10	* S11			
* E155	* E156	* E157	* E158	* E159					

* these fields are not available with COS 41

Operating matrix OOM223/253 - WX/WS with OOS31

CALIBRATION C	Ref = entry of reference value C1 (3)	Entry of calibration value current value C131	Slope is displayed 100.0 % 75.0 ... 140.0 % C132	Calibration status is displayed o.k. Exxx C133	Store calibration results yes; no; new C134
	H ₂ O = water C1 (2)	Start calibration Countdown 600 s --> 0 s C121	Calibration status is displayed o.k. Exxx C122	Store calibration results yes; no; new C123	
	on air C1 (1)	Start calibration Countdown 600 s --> 0 s C111	Calibration status is displayed o.k. Exxx C112	Store calibration results yes; no; new C113	
MEAS. VAL. DISPLAY with TEMPERATURE DISPLAY in °C Edit: Code 22 Read: any code	+	Temperature display in °F	Temperature display suppressed	Measured value in mg/l	Measured value in % Sat
		-	1st error is displayed (if present)	Other errors are displayed (up to max. 10 errors)	
SETUP 1 A	Selection of operating mode mg/l % SAT hPa A1	Selection of display unit mg/l ppm ppb A2	Automatic pressure compensation Off; On A3	Entry of altitude 0 m 0 ... 4000 m A4	Entry of measured value damping 1 (no damping) 1 ... 60 * A5
	SETUP 2 B	Entry of salt concentration 0.0 % 0.0 ... 4.0 % B1	Entry of process temperature current meas. value -10.0 ... 60.0 °C B2	Display of temp. difference (Offset) current offset -5.0 ... +5.0 °C B3	
CURRENT INPUT Z	Controller switch-off by current input Off; Input Z1	Delay for controller switch-off by current input 0 s 0 ... 2000 s Z2	Delay for controller switch-on by current input 0 s 0 ... 2000 s Z3	Switch-off limit value for current input 50% 0 ... 100% Z4	Switch-off direction for current input Low High Z5
			Tab = Table O3 (3)	Selection of table option read edit O331	Enter number of value pairs in table 1 1 ... 10 O332
CURRENT OUTPUT O	Selection of current output Out 1, Out 2 O1	Select meas. unit for 2nd current output °C; mg/l; % Sat, hPa; Contr O2	sim = Simulation O3 (2)	Entry of simulation value current value 0 ... 22.00 mA O321	
			lin = linear O3 (1)	Selection of current range 4-20 mA; 0-20 mA O311	Enter 0/4mA value 0.00 mg/l; 0...60 mg/l 0.0%Sat; 0...600% SAT 0 hPa; 0...1200 hPa 0.0 °C; -10...60 °C O312
ALARM F	Selection of contact type Latch=latching Momen=momentary F1	Selection of alarm delay unit min; s F2	Alarm delay 0 min (s) 0 ... 2000 min (s) (depends on F2) F3	Setting of error current 22 mA; 2.4 mA F4	Selection of error number! 1 1 ... 255 F5
			Alarm delay 0 min (s) 0 ... 2000 min (s) (depends on F2) P1	Setting of lower alarm threshold 0.00 mg/l; 0...59 mg/l 0.0%SAT; 0...590%SAT 0 hPa; 0...1180 hPa P2	Setting of upper alarm threshold 20.00 mg/l; 1...60 mg/l 200.0%SAT; 10...600%SAT 400 hPa; 20...1200hPa P3
CHECK P	Selection of alarm threshold monitoring Off; Low; High; Lo+Hi=low and high P1	Alarm delay 0 min (s) 0 ... 2000 min (s) (depends on F2) P2	Setting of lower alarm threshold 0.00 mg/l; 0...59 mg/l 0.0%SAT; 0...590%SAT 0 hPa; 0...1180 hPa P3	Setting of upper alarm threshold 20.00 mg/l; 1...60 mg/l 200.0%SAT; 10...600%SAT 400 hPa; 20...1200hPa P4	Setting of process monitoring off; AC; CC monitoring limit (AC): AC+CC ±0.1 mg/l ±1 % SAT ±2 hPa (in 1 h) P5

Measured value in hPa	Measured value Sensor signal in nA / mV	Measured value Current input in %	Measured value Current input in mA
--------------------------	--	--------------------------------------	---------------------------------------

only display switch!!

Selection of measuring range	
20 mg/l	60 mg/l
200%Sat	600% Sat
400 hPa	1200 hPa
A6	

Feedforward control to PID controller Off ; lin = linear Basic = basic load Z6	Feedforward control gain = 1 at 50% 0 ... 100% Z7	Selection of value pair in table 1 1 ... no. of value pairs assign O333	Entry of x-value (measured value) 0.00 mg/l ; 0...60 mg/l 0.0%SAT ; 0...600%SAT 0 hPa ; 0...1200 hPa O334	Entry of y-value (current) 0.00mA ; 0...20.00mA O335	Table status o.k. yes ; no O336
---	---	--	---	--	---

Enter 20mA value 10.00 mg/l ; 0...60 mg/l 100.0%SAT ; 0...600%SAT 200 hPa ; 0...1200hPa 40.0 °C ; -10...60 °C O313	Activate alarm contact yes ; no F6	Activate error current for previously set error no ; yes F7	Automatic start of cleaning function no ; yes F8	Selection "next error" or return to menu Next=next error <--- R F9
Setting of maximum permissible limit violation period (below limit) 480 min ; 0...2000 min P6	Setting of maximum permissible limit violation period (upper limit) 240 min ; 0...2000 min P7	Setting of limit value 5.00 mg/l ; 0...60 mg/l 50.0 %SAT ; 0...600%SAT 200 hPa ; 0...1200 hPa P8	Field for customer settings	

RELAY R	Clean = Chemoclean (with Rel3 a. Rel4 only) R2 (5)	Function R2 (5) switch on or off Off On R251	Selection of start pulse int = internal i+ext = internal + external ext = external i+stp = internal suppressed by external R252		
	Timer R2 (4)	Function R2 (4) switch on or off Off On R241	Setting of rinse time 30 s 0 ... 999 s R242	Setting of pause time 360 min 1 ... 7200 min R243	
	PID controller R2 (3)	Function R2 (3) switch on or off Aus; Ein; Basic; PID+B R231	Entry of set point 5.00 mg/l; 0...60 mg/l 50.0 %SAT; 0...600%SAT 200 hPa; 0...1200 hPa R232	Entry of control gain K _p 1.00 0.01 ... 20.00 R233	
	LC °C = limit contactor T R2(2)	Function R2 (2) switch on or off Off On R221	Entry of switch-on temperature 60 °C -10 ... 60 °C R222	Entry of switch-off temperature 60 °C -10 ... 60 °C R223	
	Select contact to be configured Rel1; Rel2; Rel3; Rel4 R1	LC PV = limit contactor O ₂ Off On R2(1)	Function R2 (1) switch on or off Off On R211	Select switch-on contact point 20.00 mg/l; 0...60 mg/l 200.0%SAT; 0...600%SAT 400 hPa; 0...1200 hPa R212	Select switch-off contact point 20.00 mg/l; 0...60 mg/l 200.0%SAT; 0...600%SAT 400 hPa; 0...1200 hPa R213
SERVICE S	Selection of language Eng; Ger; Ita; Fra; Esp; Nel S1	Hold configuration none = no hold Cal = during calibration S+C = during setup + calibration Setup = during setup S2	Manual hold Off On S2	Entry of hold dwell period 10 s 0 ... 999 s S3	
	SERVICE 2 E	Sens = sensor E1 (5)	Software version SW version E151	Hardware version HW version E152	Serial number is displayed E153
Rel = relay E1 (4)		Software version SW version E141	Hardware version HW version E142	Serial number is displayed E143	Module ID is displayed E144
MainB = main board E1 (3)		Software version SW version E131	Hardware version HW version E132	Serial number is displayed E133	Module ID is displayed E134
Trans = transmitter E1 (2)		Software version SW version E121	Hardware version HW version E122	Serial number is displayed E123	Module ID is displayed E124
Contr = controller E1 (1)		Software version SW version E111	Hardware version HW version E112	Serial number is displayed E113	Module ID is displayed E114
INTERFACE F	Entry of address Hart: 0 ... 15 or PROFIBUS: 1...126 F1	Tag description @@@@@ F2			

Entry of pre-rinse time 30 s 0 ... 999 s R253	Entry of cleaning time 10 s 0 ... 999 s R254	Entry of post-rinse time 30 s 0 ... 999 s R255	Number of repeat cycles 0 0 ... 5 R256	Setting of interval between 2 cleaning cycles (pause time) 360 min 1...7200 min R257	Setting of minimum pause time 120 min 1...3600 min R258	Number of cleaning cycles without cleaning agent 0 0 ... 9 R259	Chemoclean: uses 2 contacts, only permissible for contacts 3 (+4)		
Setting of minimum pause time 120 min 1...3600 min R244									
Entry of integral action time Tn (0.0=no I component) 0.0 s 0.0...999.9 min R234	Entry of derivative action time Tv (0.0=no D component) 0.0 s 0.0...999.9 min R235	Selection of control characteristics inv = invers dir = direct R236	Selection len = pulse length freq = pulse frequency curr = current output R237	Entry of pulse interval 10.0 s 0.5...999.9 s R238	Entry of pulse frequency 120 min⁻¹ 60 ... 180 min ⁻¹ R239	Entry of minimum on time t _{on} 0.3 s 0.1 ... 5.0 s R2310	Entry of basic load 0% 0 ... 40% R2311		
Setting of pick-up delay 0 s 0 ... 2000 s R224	Setting of drop-out delay 0 s 0 ... 2000 s R225	Setting of alarm threshold (absolute value) 60 °C -10 ... 60 °C R226	LC status MIN; MAX R227						
Setting of pick-up delay 0 s 0 ... 2000 s R214	Setting of drop-out delay 0 s 0 ... 2000 s R215	Setting of alarm threshold (abs. value) 20.00 mg/l ; 0...60 mg/l 200.0%SAT ; 0...600%SAT 400 hPa ; 0...1200 hPa R216	LC status MIN; MAX R217						
Entry of SW upgrade release code (Plus package) 0000 0000 ... 9999 S2	Entry of SW upgrade release code Chemoclean 0000 0000 ... 9999 S6	Display of order number S7	Display of serial number S8	Reset instrument to default values no: sens: factory S9	Perform instrument test no: display S10	Display of absolute air pressure S11			
Serial number sensor head existing serial no. 00000000...99999999 E155	Serial number sensor existing serial no. 00000000...99999999 E156	Order number sensor existing order no. COS31-...COS31-ZZZZ E157	Display of minimum temperature E158	Display of maximum temperature E159					

Operating matrix OOM223/253 - WX/WS with OOS71

CALIBRATION C	Ref = entry of reference value	Entry of calibration value	Slope is displayed	Calibration status is displayed	Store calibration results
	current value		100.0 % 75.0 ... 140.0 %	o.k. Exxx	yes; no; new
	C1 (3)	C131	C132	C133	C134
H ₂ O = water	Start calibration	Calibration status is displayed	Calibration status is displayed	Store calibration results	
	Countdown 600 s --> 0 s	o.k. Exxx	yes; no; new		
C1 (2)	C121	C122	C123		
on air	Start calibration	Calibration status is displayed	Calibration status is displayed	Store calibration results	
	Countdown 600 s --> 0 s	o.k. Exxx	yes; no; new		
C1 (1)	C111	C112	C113		
MEAS. VAL. DISPLAY with TEMPERATURE DISPLAY in °C	+	Temperature display	Temperature display	Measured value	Measured value
	-	in °F	suppressed	in mg/l	in % Sat
Edit: Code 22 Read: any code		1st error is displayed (if present)	Other errors are displayed (up to max. 10 errors)		
SETUP 1 A	Selection of operating mode	Selection of display unit	Automatic pressure compensation	Entry of altitude	Entry of measured value damping
	mg/l % SAT hPa	mg/l ppm ppb	Off; On	0 m 0 ... 4000 m	1 (no damping) 1 ... 60
A1	A2	A3	A4	A5	
SETUP 2 B	Entry of salt concentration	Entry of process temperature	Display of temp. difference (Offset)	* these fields are not available with DX versions	
	0.0 % 0.0 ... 4.0 %	current meas. value -10.0 ... 60.0 °C	current offset -5.0 ... +5.0 °C		
B1	B2	B3			
CURRENT INPUT Z	Controller switch-off by current input	Delay for controller switch-off by current input	Delay for controller switch-on by current input	Switch-off limit value for current input	Switch-off direction for current input
	Off; Input	0 s 0 ... 2000 s	0 s 0 ... 2000 s	50% 0 ... 100%	Low; High
Z1	Z2	Z3	Z4	Z5	
CURRENT OUTPUT O	Selection of current output	Select meas. unit for 2nd current output	lin = linear	Selection of current range	Enter 0/4mA value
	Out 1, Out 2	°C; mg/l; % Sat, hPa; Contr		4-20 mA; 0-20 mA	0.000 mg/l; 0...20 mg/l 0.0%Sat; 0...200% Sat 0 hPa; 0...400 hPa 0.0 °C; -10...60 °C
O1	O2	O3 (1)	O311	O312	
ALARM F	Selection of contact type	Selection of alarm delay unit	Alarm delay	Setting of error current	Selection of error number
	Latch=latching Momen=momentary	min; s	0 min (s) 0 ... 2000 min (s) (depends on F2)	22 mA; 2.4 mA	1 1 ... 255
F1	F2	F3	F4	F5	
CHECK P	Selection of alarm threshold monitoring	Alarm delay	Setting of lower alarm threshold	Setting of upper alarm threshold	Selection of process monitoring
	Off; Low; High; Lo+Hi=low and high	0 min (s) 0 ... 2000 min (s) (depends on F2)	0.000 mg/l; 0...19 mg/l 0.0%SAT; 0...190%SAT 0 hPa; 0...380 hPa	20.000 mg/l; 1...20 mg/l 200.0%SAT; 10...200%SAT 400 hPa; 20...400hPa	AC+CC ±0.1 mg/l ±1 % SAT ±2 hPa (in 1 h)
P1	P2	P3	P4	P5	

Measured value in hPa	Measured value Sensor signal in nA / mV	Measured value Current input in %	Measured value Current input in mA
--------------------------	--	--------------------------------------	---------------------------------------

only display switch!!

Selection of measuring range	
20 mg/l	60 mg/l
200%Sat	600% Sat
400 hPa	1200 hPa
A6	

Feedforward control to PID controller Off ; lin = linear Basic = basic load Z6	Feedforward control gain = 1 at 50% 0... 100% Z7	Selection of value pair in table 1 1 ... no. of value pairs assign O333	Entry of x-value (measured value) 0.00 mg/l ; 0...20 mg/l 0.0%SAT ; 0...200%SAT 0 hPa ; 0...400 hPa O334	Entry of y-value (current) 0.00mA ; 0...20.00mA O335	Table status o.k. yes ; no O336
---	--	--	--	--	---

Enter 20mA value 10.000 mg/l ; 0...20 mg/l 100.0%SAT ; 0...200%SAT 200 hPa ; 0...400hPa 40.0 °C ; -10...60 °C O313				
Activate alarm contact yes ; no F6	Activate error current for previously set error no ; yes F7	Automatic start of cleaning function no ; yes F8	Selection "next error" or return to menu Next=next error <--- R F9	
Setting of maximum permissible limit violation period (below limit) 480 min ; 0...2000 min P6	Setting of maximum permissible limit violation period (upper limit) 240 min ; 0...2000 min P7	Setting of limit value 1.000 mg/l ; 0...20 mg/l 50.0 %SAT ; 0...200%SAT 20 hPa ; 0...400 hPa P8	Field for customer settings	

RELAY R	Clean = Chemoclean (with Rel3 a. Rel4 only) R2 (5)	Function R2 (5) switch on or off Off On R251	Selection of start pulse int = internal i+ext = internal + external ext = external i+stp = internal suppressed by external R252		
	Timer R2 (4)	Function R2 (4) switch on or off Off On R241	Setting of rinse time 30 s 0 ... 999 s R242	Setting of pause time 360 min 1 ... 7200 min R243	
	PID controller R2 (3)	Function R2 (3) switch on or off Off; On; Basic; PID+B R231	Entry of set point 5,000 mg/l; 0...20 mg/l 50,0 %SAT; 0...200%SAT 200 hPa; 0...400 hPa R232	Entry of control gain K _p 1.00 0.01 ... 20.00 R233	
	LC °C = limit contactor T R2(2)	Function R2 (2) switch on or off Off On R221	Entry of switch-on temperature 60 °C -10 ... 60 °C R222	Entry of switch-off temperature 60 °C -10 ... 60 °C R223	
	Select contact to be configured Rel1; Rel2; Rel3; Rel4 R1	LC PV = limit contactor O ₂ R2(1)	Function R2 (1) switch on or off Off On R211	Select switch-on contact point 20,000 mg/l; 0...20 mg/l 200,0%SAT; 0...200%SAT 400 hPa; 0...400 hPa R212	Select switch-off contact point 20,000 mg/l; 0...20 mg/l 200,0%SAT; 0...200%SAT 400 hPa; 0...400 hPa R213
SERVICE S	Selection of language Eng; Ger; Ita; Fra; Esp; Nel S1	Hold configuration none = no hold Cal = during calibration S+C = during setup + calibration Setup = during setup S2	Manual hold Off On S2	Entry of hold dwell period 10 s 0 ... 999 s S3	
	SERVICE 2 E	Sens = sensor E1 (5)	Software version SW version E151	Hardware version HW version E152	Serial number is displayed E153
Rel = relay E1 (4)		Software version SW version E141	Hardware version HW version E142	Serial number is displayed E143	Module ID is displayed E144
MainB = main board E1 (3)		Software version SW version E131	Hardware version HW version E132	Serial number is displayed E133	Module ID is displayed E134
Trans = transmitter E1 (2)		Software version SW version E121	Hardware version HW version E122	Serial number is displayed E123	Module ID is displayed E124
Contr = controller E1 (1)		Software version SW version E111	Hardware version HW version E112	Serial number is displayed E113	Module ID is displayed E114
INTERFACE F	Entry of address Hart: 0 ... 15 or PROFIBUS: 1...126 F1	Tag description @@@@@ F2			

Entry of pre-rinse time 30 s 0 ... 999 s R253	Entry of cleaning time 10 s 0 ... 999 s R254	Entry of post-rinse time 30 s 0 ... 999 s R255	Number of repeat cycles 0 0 ... 5 R256	Setting of interval between 2 cleaning cycles (pause time) 360 min 1...7200 min R257	Setting of minimum pause time 120 min 1...3600 min R258	Number of cleaning cycles without cleaning agent 0 0 ... 9 R259	Chemoclean: uses 2 contacts, only permissible for contacts 3 (+4)		
Setting of minimum pause time 120 min 1...3600 min R244									
Entry of integral action time Tn (0,0=no I component) 0.0 s 0.0...999.9 min R234	Entry of derivative action time Tv (0,0=no D component) 0.0 s 0.0...999.9 min R235	Selection of control characteristics inv = invers dir = direct R236	Selection len = pulse length freq = pulse frequency curr = current output R237	Entry of pulse interval 10.0 s 0.5...999.9 s R238	Entry of pulse frequency 120 min⁻¹ 60 ... 180 min ⁻¹ R239	Entry of minimum on time t _{on} 0.3 s 0.1 ... 5.0 s R2310	Entry of basic load 0% 0 ... 40% R2311		
Setting of pick-up delay 0 s 0 ... 2000 s R224	Setting of drop-out delay 0 s 0 ... 2000 s R225	Setting of alarm threshold (absolute value) 60 °C -10 ... 60 °C R226	LC status MIN; MAX R227						
Setting of pick-up delay 0 s 0 ... 2000 s R214	Setting of drop-out delay 0 s 0 ... 2000 s R215	Setting of alarm threshold (abs. value) 20.000 mg/l ; 0...60 mg/l 200.0%SAT ; 0...600%SAT 400 hPa ; 0...1200 hPa R216	LC status MIN; MAX R217						
Entry of SW upgrade release code (Plus package) 0000 0000 ... 9999 S2	Entry of SW upgrade release code Chemoclean 0000 0000 ... 9999 S6	Display of order number S7	Display of serial number S8	Reset instrument to default values no ; sens; factory S9	Perform instrument test no ; display S10	Display of absolute air pressure S11			
Serial number sensor head existing serial no. 00000000...99999999 E155	Serial number sensor existing serial no. 00000000...99999999 E156	Order number sensor existing order no. COS71-...COS71-ZZZZ E157	Display of minimum temperature E158	Display of maximum temperature E159					

Index

A

Access codes	33
Accessories	74
Alarm contact	27
Alarm threshold monitoring	49
Appendix	
Operating matrix	98
Automatic mode	32

C

Calibration	66
Check	49
Checking	
Connections	27
Function	35
Installation	14
Chemoclean function	56
Cleaning	
Transmitter	70
Commissioning	4, 35
Communication	66
Connection diagram	16
Controller monitoring	49
Controller replacement	92
Current input	40
Current outputs	43

D

Declaration of conformity	7
Designated use	4
Diagnosis code	78
Dismantling	
Field instrument	89
Panel mounted instrument	86
Display	28
Disposal	92

E

Electrical connection	
Without Memosens	15
Electrical icons	5
EMC	4
Environment	95

F

Factory settings	36
Field device connection	17, 21, 24, 26
Flow assembly	76
Freezing of outputs	34

H

Hold function	34, 63
---------------------	--------

I

Icons	
Electrical	5
Safety symbols	5
Immersion assembly	76
Incoming acceptance	9
Input	93
Installation	4, 8–9, 11
Instrument specific errors	84
Interfaces	66

K

Key assignment	30
----------------------	----

L

Limit contactor	52
-----------------------	----

M

Maintenance	70
Assembly	72
Connecting lines and junction boxes	73
Entire measuring point	70
Oxygen sensors	72
Manual mode	32
Measuring cable	
Variant 1	18
Measuring system	8
Mechanical construction	96
Menu structure	34
Monitoring functions	48

O

Operating elements 29
 Operating matrix 98
 Operating modes 33
 Operation 4
 Display 28
 Operating concept 32
 Operating elements 29
 Operational safety 4
 Optoscope 73
 Ordering information 6
 Output 93

P

P controller 53
 PD controller 53
 Performance characteristics 95
 PI controller 53
 PID controller 53
 Plus package 6
 Post mounting 12
 Power supply 94
 Process specific errors 81
 Product structure 6

Q

Quick commissioning 37
 Quick setup 37
 Quick start-up 28, 37

R

Relay contact configuration 52
 Replacement of controller 92
 Retractable assembly 76
 Return 5, 92

S

Safety icons 5
 Scope of delivery 7
 Sensor activity monitoring 49
 Service 63
 Service 2 65
 Setup 1 (oxygen) 39
 Setup 2 (salinity and temperature) 40
 Spare parts 86
 Storage 9
 Switching on 35
 Symbols 5
 System configuration 39
 System error messages 78

T

Technical data 93
 Test
 Variant 1 (DX/DS) 71
 Variant 2 (WX/WS) 72
 Timer for cleaning function 56
 Transport 9
 Trouble-shooting
 Instructions 78
 Instrument specific errors 84
 Process specific errors 81
 System error messages 78

U

Use
 designated 4

W

Wall mounting 11
 Wiring 15

